

# GET IN AND GO

The wheel and telescopic wheel loaders  
5035 / 5040 / 5050 / 5055 / 5065 / 5065T



**KRAMER**  
*on the safe side*



## A broad range of application areas

Discover the all-wheel wheel loaders and telescopic wheel loaders in the 0.35 to 0.65 m<sup>3</sup> class

The compact equipment is the main segment of Kramer-Werke GmbH. The efficient machines have been planned down to the finest detail and impress with the tried-and-tested design principle, which provides unbeatable manoeuvrability. Due to their narrow and low design, the machines are also in demand where large machines can't fit: tight access roads, work in landscaped gardens or confined road construction sites.

## On the safe side with Kramer

Rich in tradition, the Kramer brand has been established on the market for many years and in particular stands for one value: **Safety**. The high quality of the innovative machines is only one aspect of this. Kramer is also a safe choice as a company for customers and dealers because its experience and innovations ensure secure investments and security for the future. In short – you are always on the safe side with Kramer: **“Kramer – on the safe side!”**

➔ **ON THE SAFE SIDE**

## Table of contents

### Vehicle structure

One-piece vehicle frame  
Advantages at a glance  
Types of steering

**04**

### Compact design

Power to weight ratio  
Dimensions  
Transport possibilities

**08**

### Drive train

Engines  
Exhaust emission after-treatment systems  
Performance curves

**10**

### Wheel loaders and telescopic wheel loaders at a glance

Wheel loader: 5035, 5040,  
5050, 5055, 5065  
Telescopic wheel loader: 5065T

**12**

### Machine Highlights 5035, 5040

Cabin design  
Loader unit  
Hydraulic

**14**

### Machine Highlights 5050 - 5065T

Smart Ballast (5050)  
Cabin design  
Loader units

**20**

### Machine components and accessories

Attachments  
Quickhitch system  
Tyres

**28**

### Technical Data and Dimensions

**32**



#### Operating and performance data wheel

LOADERS AND TELESCOPIC WHEEL LOADERS	5035	5040	5050	5055
Engine output (optional) [kW]	18.5	28.5	34.3	34.3 (41.1)
Bucket capacity [m <sup>3</sup> ]	0.35	0.36	0.45	0.55
Lift capacity [kN]	11.5	15.8	37.0	32.5
Bucket tipping load [kg]	1,200	1,400	1,800	1,980
Payload on pallet forks S=1.25 [kg]	750	900	1,200	1,600
Net weight [kg]*	1,700 - 2,200	1,900 - 2,400	2,850 - 3,300	3,200 - 4,300

\* Weight as standard with full tank, incl. standard bucket weight (without operator)

	5055L	5065	5065L	5065T
Engine output (optional) [kW]	34.3 (41.1)	34.3 (41.1)	34.3 (41.1)	34.3 (41.1)
Bucket capacity [m <sup>3</sup> ]	0.55	0.65	0.65	0.65
Lift capacity [kN]	26.5	32.5	26.5	32.5
Bucket tipping load [kg]	1,780	2,340	2,140	2,500
Payload on pallet forks S=1.25 [kg]	1,450	1,750	1,600	1,650
Operating weight [kg]*	3,200 - 4,300	3,200 - 4,300	3,200 - 4,300	3,500 - 4,600

# Why split what belongs together?

## Kramer – A unique system

The Kramer brand stands for all wheel steer loaders, telescopic wheel loaders and telehandlers with extreme manoeuvrability, all-terrain mobility and high efficiency. The wheel loaders impress with their high level of stability thanks to the time-tested and proven, one-piece vehicle frame.

Due to this special vehicle setup, there is no shifting of the centre of gravity through steering movements. Only the wheels move when steering due to the Ackermann steering. Thus, high stability is given even with a tight turning circle, on uneven ground conditions and with maximum payloads.

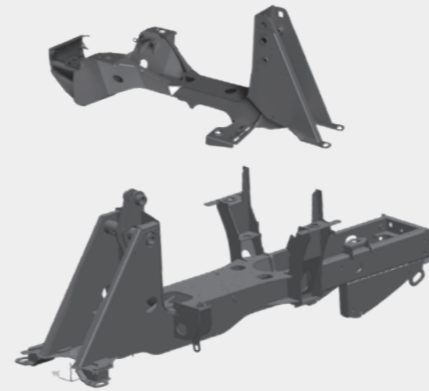

## The benefits at a glance

### High level of stability

The wheel loaders and telescopic wheel loaders are designed with a one-piece chassis that prevents shifts in the centre of gravity – even with a full steering lock. This makes the vehicles with a high level of stability convincing – even in uneven ground conditions.

### Enormous manoeuvrability

The all-wheel steering and the steering angle of 38 degrees on the front and rear axle allow you a high degree of manoeuvrability. Some steering manoeuvres therefore become unnecessary, resulting in shorter cycle times.

### Constant payload

The undivided chassis prevents the distance between the counterweight and the loader unit from changing. The result: constant leverage that makes working safe in all load situations. In the process, the payload always stays the same, independent of the steering angle.

### Undivided chassis for a high level of stability ...

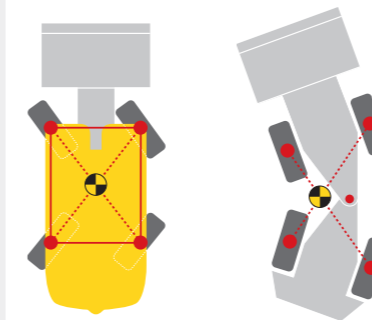

... without a shift in the centre of gravity.

### Turning made easy with all-wheel steering ...

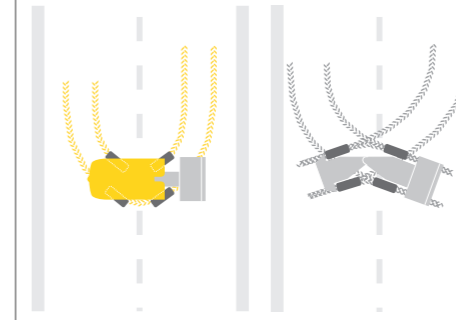

... instead of time-consuming manoeuvring with an articulated joint.

### Constant leverage for constant payload

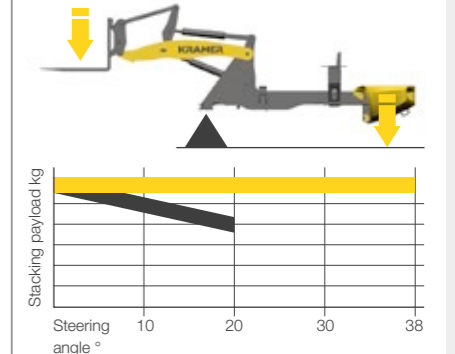

■ Kramer  
■ Competition (articulated)

## Flexibility in application

### The right type of steering system for any application

The one-piece vehicle frame forms the basis for three (5035, 5040) and two (5050 - 5065T) different steering types. A wheel loader's design principle decides how it is used and for which applications. The steering system is the crucial factor here.



#### All-wheel steering

- 2 x 38 degree steering angle on the front and rear axle ensure quick work processes
- optimised routes
- tight turning circle



#### Front wheel steering (option)

- safe and familiar road travel at high speed
- easy guidance of special attachments
- familiar steering system
- ideal for trailer operation

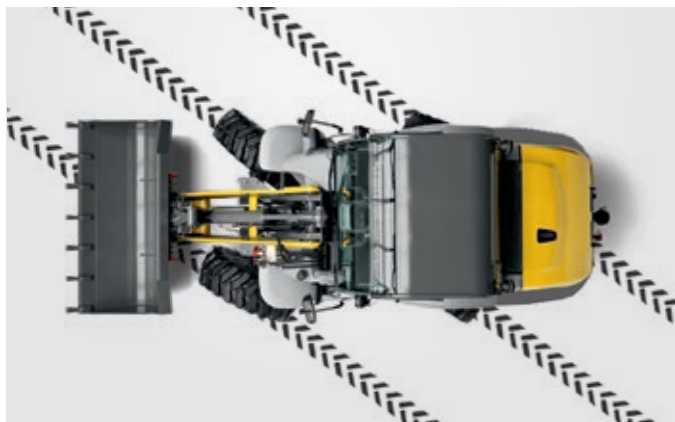

#### Crab steering (optional)\*

- manoeuvrability in the smallest space
- precise positioning in the tightest conditions
- ground protection for sensitive subbase
- easily move away from walls and trenches

\* available for the models 5035 and 5040



All-wheel steering: particularly manoeuvrable in tight spaces

#### All-wheel and articulated steering in a comparison

Example: 360° turning manoeuvre over outer edge of tyres

With the all-wheel steering, the turning circle is much smaller compared to the articulated steering (see yellow line). This is achieved by the steering lock on the front and rear axle, while only the front carriage moves with the articulated steering.

■ All-wheel steering

■ Articulated steering (competition)

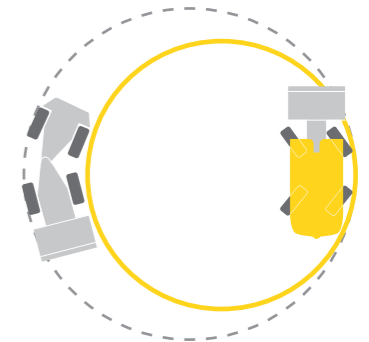

# Compact dimensions and optimal power to weight ratio

## Power in a perfect proportion

The compact wheel loaders and telescopic wheel loaders by Kramer are among the most versatile machines on the construction site. With their dimensions, they are ideal for low clearance heights and tight passages, making them indispensable companions.

The design principle of the undivided vehicle frame is responsible for the extremely compact dimensions. In addition, excellent power ratings are achieved due to the ratio of operating weight, payload and tipping load, which are unparalleled in this vehicle class.



**5035 and 5040:**  
Even suitable for work in underground car parks or multi-storey car parks



### Top performance of the dimensions and power to weight ratio:

- perfect ratio between payload and operating weight
- easily transport on 3.5 t trailers (5035, 5040, 5050)
- economic use that saves time and fuel thanks to the small turning radius
- economic power to weight ratio



### Trailer transport

Due to the low overall height of less than 2.5 m and their very low dead weight, the machines can be quickly and easily transported from site of application to site of application. To do this, both 3.5 t trailers and 7.49 t trucks can be used. When transporting by truck, the overall height remains below 4 m. This increases the company's flexibility and reduces the machine downtimes.

Transport means*	5035	5040	5050	5055
Trailer - 3.5 t	x	x	x	-
Truck - 7.49 t	x	x	x	x
Shipping weight**	1,700	1,900	2,645	3,200

\* Can deviate depending on the towing vehicle model and equipment, as well as the machine's equipment  
\*\* Basic equipment without attachment, without operator, full tank (weight varies depending on equipment)

x = permissible      - not permitted

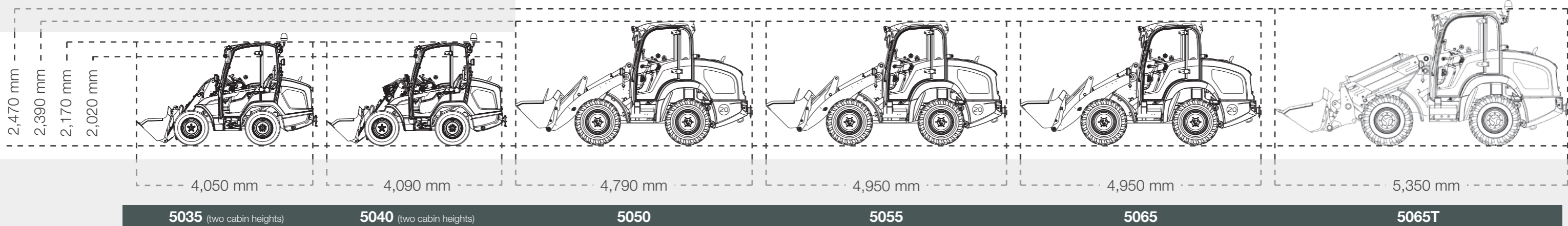

# Powerful engines

## Efficient fuel consumption

The 5035 and 5040 wheel loaders are both equipped with exhaust emission Stage V Yanmar engines. The 5035 is driven by an 18.5 kW engine without an exhaust emission after-treatment. The even more performance efficient 5040 is available with a 28.5 kW engine. Here, the exhaust emissions are treated with DOC, DPF.

The models 5050 through to 5065T likewise have a Yanmar engine and fulfil the exhaust emission stage V. The engines with 34.3 kW (standard) and 41.1 kW (optional for 5055, 5065, 5065T) are equipped with a DOC and DPF.

### Top performance of the engines:

- high torque and economical engines by Yanmar
- modern exhaust emissions after-treatment with DOC + DPF
- newest engine technology with exhaust emission Stage V

	5035	5040	5050	5055	5065	5065T
<b>Overview of engines</b>	Standard	Standard	Standard	Standard (Option)	Standard (Option)	Standard (Option)
Engine manufacturer	Yanmar	Yanmar	Yanmar	Yanmar	Yanmar	Yanmar
Output [kw/hp]	18.5/25	28.5/39	34.3/46	34.3/46 (41.1/55)	34.3/46 (41.1/55)	34.3/46 (41.1/55)
Exhaust after-treatment system	-	DOC+DPF	DOC+DPF	DOC+DPF	DOC+DPF	DOC+DPF
Exhaust emissions stage (EU exhaust emissions standard)	Stage V	Stage V	Stage V	Stage V	Stage V	Stage V



Optimised running smoothness: economical and powerful engines in all Kramer models.

### Exhaust emission after-treatment systems

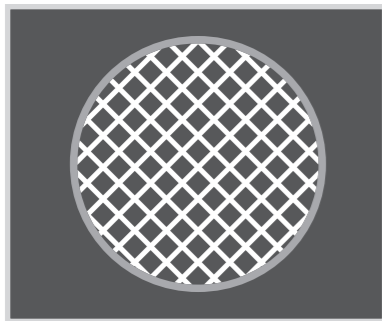

#### Diesel oxidation catalytic converter (DOC)

Catalytic converters are used these days to reduce emissions in many cars and lorries. The diesel oxidation catalytic converter has the same functionality. Without the movement of mechanical parts, it triggers chemical processes that reduce emissions.

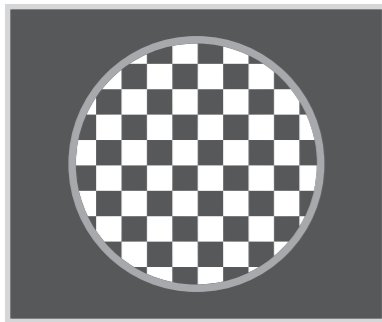

#### Diesel particulate filter (DPF)

The diesel particulate filter is used in connection with an oxidation catalytic converter to remove most of the nitrogen oxides, soot particles and non-combusted hydrocarbons from the combusted diesel fuel. The diesel particulate filter contains a porous honeycomb structure that catches the soot when it passes through. When the soot has accumulated to a certain extent, the machine's electronic system triggers fuel injections, which bring the non-combusted fuel into the oxidation catalytic converter, which is located before the filter. There it triggers an exothermic reaction that heats the exhaust emissions so much that the soot in the diesel particulate filter is combusted. This process is also known as regeneration.

Performance curve of Yanmar 3TNV82A-B; 18.5 kW; Stage V (standard)

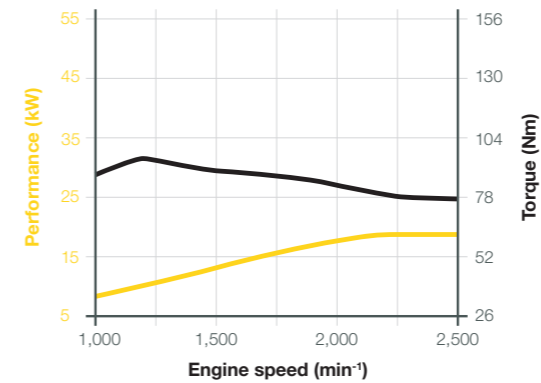

Performance curve of Yanmar 3TNV86CT; 28.5 kW; Stage V (standard)

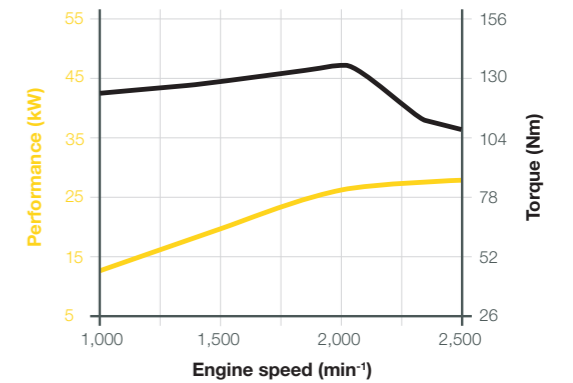

Performance curve of Yanmar 4TNV88C; 34.3 kW; Stage V (standard)

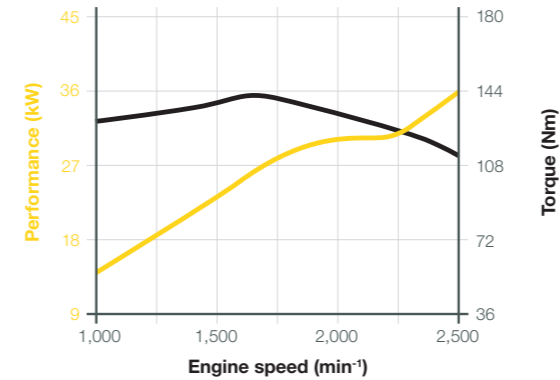

Performance curve of Yanmar 4TNV86CT; 41.1 kW; Stage V (option)

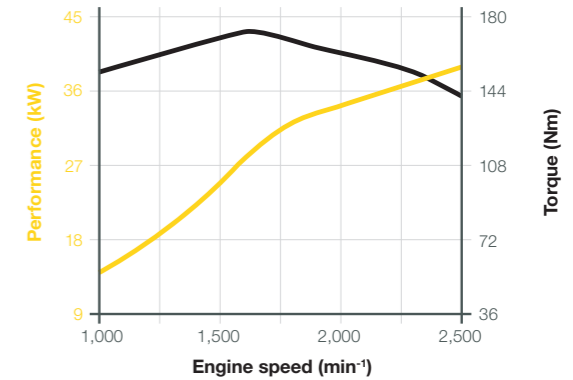

## Made for application

Discover the product range of the compact class

The wheel loaders: 5035, 5040

The 5035 and 5040 wheel loaders are the smallest models by Kramer. When designing and developing, the focus was on the simple and intuitive operation, which makes everyday work much easier for the operator. With their very compact design, they are great helpers when working in confined spaces. The machines are versatile in use thanks to their overall height and also allow for applications inside buildings, such as working in underground car parks. The machines can easily be transported on 3.5 tonne trailers thanks to their very low dead weight.



Modern design, technology, performance and comfort: Kramer wheel loaders set the standard!

**Top performance telescopic wheel loader 5065T:**

**+ 50% stroke and dumping height**

**+ 42% stacking height**

**+ 38% load-over height**

e.g. for storing materials, stacking pallets, filling high-walled lorries, trailers or containers

The wheel loaders and telescopic wheel loaders: 5050, 5055, 5065, 5065T

The wheel loaders and telescopic wheel loaders of the compact class are agile in their movements, dynamic in their power delivery and slim in their design. With the optimised power to weight ratio, low shipping weight and constantly high payload, they are the ideal helpers on construction sites in road and highway construction, civil engineering, and gardening and landscaping.

With the Kramer telescope technology of the 5065T, even greater lift heights and reaches are reached comfortably, safely and precisely. This significantly improves productivity and economic efficiency.



## Modern cabin design

### First-class comfort

The innovative cabin design ensures added-value in terms of comfort and operator-friendliness within the compact wheel loader segment, whereby the functionality and ergonomics are at the forefront.

Large areas of glass combined with narrow cabin pillars ensure excellent all-round visibility. The special hydraulic oil and diesel tank shape under the front window enables the operator perfect visibility of the attachment. There are many functional and ergonomic features, as well as numerous storage compartments in the side console. Furthermore, all of the important colour-coded switches are placed within reach of the right hand.



**Comfortable joystick:**  
Possible to switch between hare and tortoise on the joystick itself.



A spacious, quiet and extensively glazed cabin provides the perfect conditions to get through everyday operations safely.

## Technical highlights

### Simple operation – Innovative cabin design

#### Cabin entry



The wide entry includes additional steps, thus ensuring a comfortable entry and exit. Two handles attached to the cabin aid the operator in safely getting to their working area. Furthermore, the cabin door can be opened 180 degrees and can be locked to the machine.

#### Smart Driving PRO



The feature on the 5040 includes three operator modes that can be changed by pressing a button in order to meet the respective requirements most efficiently. The Power Mode (PWR) is suited to bucket work, the ECO Mode to stacking work or road travel and the low-speed control (CSD) to hydraulic attachments.

#### Steering column



The optional incline-adjustable steering column can be adapted to the operator's needs. The steering wheel is made of a high-quality and non-slip material. Furthermore, there is a modern visual display with automatic indicator reset on the steering column.

#### Centre tunnel



The centre tunnel in the cabin floor has a height of just 5 cm thanks to the design of the vehicle frame. Thus enabling the operator comfortable entry and exit. The centre tunnel is likewise covered with a rubber mat and can be easily cleaned.

#### Cleaning flap



The cleaning flap is on the right side of the cabin. The flap is opened upwards using a handle and is fixed by an attenuator. Simple access is thus provided to the cabin air filter and the main control unit. Cleaning the cabin floor can be performed very easily.

#### Other cabin features



A continental radio with USB connection and Bluetooth hands-free system is available as an option. The temperature and ventilation regulation is positioned in the side console. The optional air-conditioning system for the 5040 ensures a comfortable climate, even on the warmer days. Furthermore, the vehicle can be equipped with an automatic engine stop via seat contact.



## Different loader units

### Work easily with loads

The loader units for both machines are made of a high-strength and torsion-resistant box profile. The large lift and tearout forces, as well as parallel guidance of pallet forks throughout the total height are achieved with Z-kinematics. The loader unit's even more sturdy construction for the 5040 ensures even higher payload.

The automatic load stabiliser is optionally available. The load stabiliser dampens oscillations of the loader unit and ensures maximum operational comfort. The safe handling of heavy loads is therefore also guaranteed on uneven ground conditions. The automatic function automatically switches on the load stabiliser after a speed of 8 km/h (transport operation) or automatically switches it off under 8 km/h (loading operation). In addition, it is possible to continuously enable or disable the load stabiliser for certain applications.

The visual position display for the fork (yellow) and bucket (red) can be found on the rocker arm, as well as the tilt rod and indicates the position of the bucket and fork. As a result, a high level of precision is achieved in the inclination angle of the attachment to the ground. The position indication is a great benefit, particularly to the inexperienced operator or where operators are constantly changing, such as in a plant hire business parks.

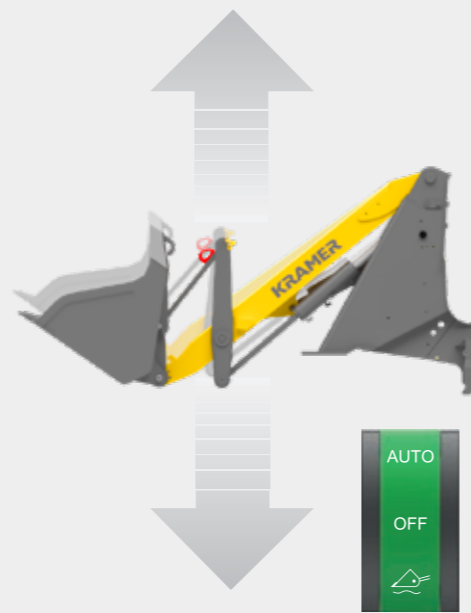

**Automatic load stabiliser** prevents the machine from swaying and reduces material loss.

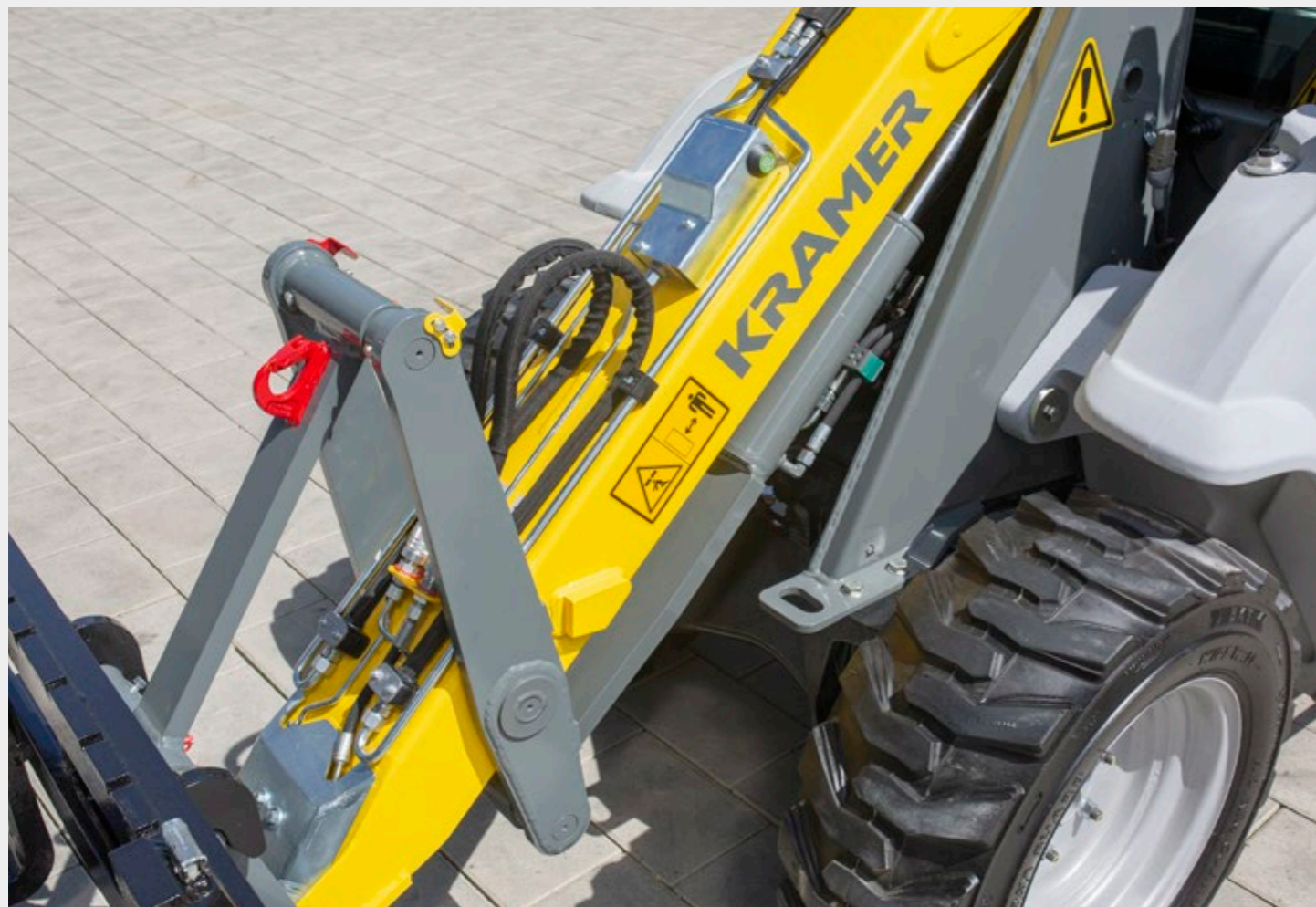

**Sturdy loader unit** with Z-kinematics, visual position display and optional load hook.

### Top-performance wheel loaders 5035 and 5040:

- powerful lift capacity:  
5035 - 11.5 kN  
5040 - 15.8 kN
- spacious cabin with very good all-round visibility and a variety of options
- three types of steering for maximum flexibility
- Smart Driving PRO with the option of three operating modes for the 5040
- low-cabin available optionally as canopy or cabin version



### Two cabin heights

It is possible to choose between two cabin heights. The low cabin with a height of 2.02 m ensures maximum vehicle compactness and is optionally available as a canopy or cabin version. The high cabin with a height of 2.17 m provides even better all-round visibility and creates the highest level of comfort for the operator.

### Powerflow

The 5040 wheel loader continues to impress with optional powerflow auxiliary hydraulics. The hydraulics are in a compact design on the left-hand side of the loader unit and ensure perfect visibility of the attachment. No matter whether used with a snow blower, a mulcher, a plate compactor or a cultivation device - the 5040 is diversely applicable with the powerflow function and ready for use in each application during the year.



Concept solution for system bearer	5035	5040
3rd control circuit [l/min]*	20	30
Power flow performance hydraulics [l/min]*	-	56

\*max. pump values

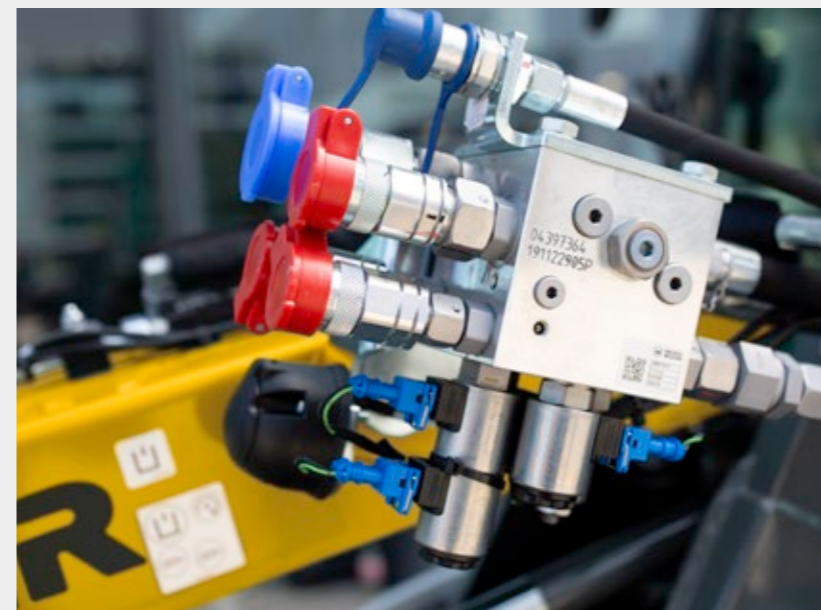

### Pressure release of 3rd control circuit

The button for optional pressure release of the 3rd control circuit is centrally fitted to the loader unit. As a result, different attachments can be quickly and efficiently changed without the need to switch off the engine.

# Machine highlights of the 5035 / 5040

## The compact genius among wheel loaders

**Smart Driving PRO (5040)**  
Three operating modes that can be changed at the press of a button (PWR - Power Mode, ECO - Eco Mode and CSD - low-speed control) support the operator in the respective applications.

**Flexible in application**  
with a standard 3rd control circuit integrated into the joystick and optional pressure release lever on the loader unit. The Powerflow for the 5040 adds a powerful drive to the hydraulic attachments.

**Loader unit with Z-kinematics:**  
for high lift capacities and tear-out forces and an exact parallel guidance over the entire lift height.

**Work efficiently**  
thanks to the hydraulic quickhitch system, load stabiliser and visual position display for bucket and fork.

**Three steering types**  
support maximum manoeuvrability. All-wheel steering as standard and the optional steering types like front wheel and crab steering provide more in terms of flexibility. Switching between the steering types is carried out mechanically.

**Two cabin heights (2.02 m / 2.17 m)**  
for maximum compactness and maximum comfort.

**Innovative cabin design**  
Glazed areas ensure optimal visibility. The wide step and the door which locks to the rear provide comfortable entry and exit. The side console contains many functional and ergonomic features. Optionally available, among others, is the incline-adjustable steering column.

**The two speed levels**  
can be easily changed while driving. With the 5040, the drive is also available with speeds up to 30 km/h.

**Two engine classes**  
by Yanmar with exhaust emission Stage V. 5035 is equipped with an 18.5 kW engine and 5040 with a 28.5 kW engine incl. DOC and DPF.

**Four wheel hub motors**  
for sensitive work and high pushing power.

**One-piece vehicle frame**  
for great manoeuvrability during constant stability.

**Large selection of tyre options**  
for a wide range of application areas.



## Stacking at its best

### Maximum flexibility in everyday work

The Kramer wheel loader 5050 is particularly distinguished by its low dead weight. The machine weight can be adapted to every work situation due to the optional additional weight Smart Ballast, which is simply and inconspicuously positioned in the tail. With its manoeuvrability, high payload, stack tipping load and transportability, the machine is suitable for different application areas.

The service package is rounded off by safety, comfort and a variety of options which allow for application year-round.

**Special design of the loader unit** ensure high lift and tearout forces. Commercial stone pallets can be moved without any trouble.

**5050**



### Top-performance wheel loader 5050:

- powerful lift capacity of 37 kN
- perfect performance characteristics of 34.3 kW / 46 hp
- optimal transport weight of 2,685 kg incl. cabin
- high bucket pivotal point of 2,840 mm
- flexible Smart Ballast weights of a total of 100 kg



### Smart Ballast - optional additional weights in the tail

The Smart Ballast weights enable adaptation of the machine's weight or the stack tipping load up to 1,700 kg depending on the user requirement, whereby it is possible to flexibly switch between the working and transportation situation.

The Smart Ballast weights in total weigh 100 kg. Each of the eight weights weighs a portable 12.5 kg.

### Trailer transport

The low dead weight without Smart Ballast and the compact dimensions of the machine enable easy transportation on a 3.5 t trailer. The Smart Ballast weights can be transported in a towing vehicle. A class BE driver's licence is required.

With the portfolio expansion with a custom-made trailer, which enables perfect load securing with rapid action couplings, there is nothing to stand in the way of this wheel loader 5050, which provides complete flexibility. Your competent Kramer dealer will be happy to help you.



Quick and easy load securing with the locking of the Kramer quick-hitch system directly on the trailer.

## Working comfortably

### For ideal working conditions

Simple operation and functionality are the focus of the machine series. From the operator's seat to the steering wheel, all the details are aligned with the needs of the operator. The operator has plenty of room and everything is always in view here.

The compact wheel and telescopic wheel loaders from Kramer have proven to be real space miracles in terms of cabin technology and their equipment ensures fatigue-free working for many hours. The clearly arranged operator's controls create an environment in which the operator's controls can work comfortably, focused and productively. The joystick, as the heart of the machine, provides secure, simple and intuitive operation.

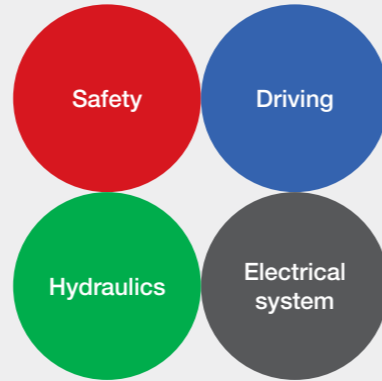

Colour-coding of the switches: four colours for even more safety.



Panoramic cabin for an excellent overview of the attachment and the working environment.

## Technical highlights

### Simple operation – Innovative cabin design



Cabin entry

The cabin can be accessed through the large entry area. The undivided vehicle frame also makes it possible to comfortably enter at maximum steering lock. The entry is designed like steps. The grab handles are in an ergonomically favourable position to make it easier for the operator to enter and exit.

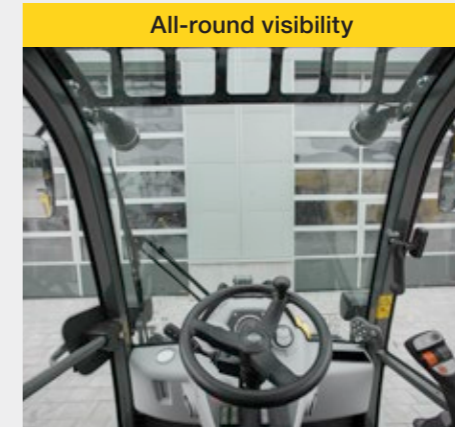

All-round visibility

The central seat position of the operator offers a 360° all-round visibility. "Blind spots" are avoided thanks to the particularly clearly arranged design. You can even see everything to the rear. Even when the telehandler system is extended on the 5065T, the operator has a perfect view of the attachment.



Vehicle height

The machines offer the best prerequisites for low headrooms. All machines have a total height of under 2.5 m. It is possible to easily transport on a 3.5 t trailer due to the compact design of the 5050 wheel loader.

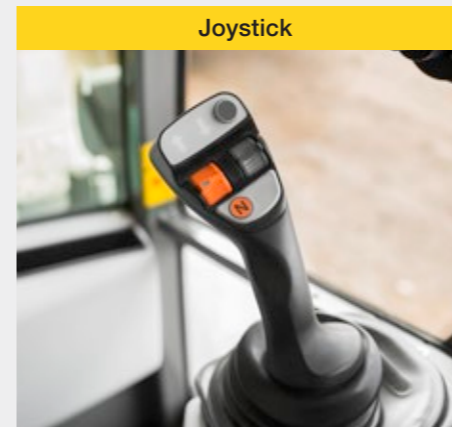

Joystick

The joystick shows its strengths above all when things get dark. In the night design, the different touch buttons and wheels light up in different colours. The operator can then immediately identify the respective function and his vehicle is safely under control.



Switch concept

The respective functional group is very quick and easy to identify due to the colour-coded switches. Red = safety, green = hydraulics, blue = travel and grey = electrical system. This ensures the operator a convenient and safe operation without the risk of being confused. The result is increased working efficiency for the operator.



Other cabin features

The powerful heater with window ventilation and heating nozzles in the foot well ensures comfortable working, even on cold days. A fully integrated air-conditioning system is optionally available. The combined brake-inch pedal allows for precise manoeuvring, even at high engine speed.

## Powerful hydraulics

### For sensitively controlling the machine

Connect and disconnect different attachments, sensitive control, quick working cycles and all of this with a low noise level in the cab: The technology behind the work hydraulics of our machines makes this possible.

The work hydraulics are powered by powerful gear pumps, which ensure quick working cycles of the loader unit and allow for the operation of special attachments via the 3rd control circuit, if necessary with continuous function.

**Pressure release of 3rd control circuit:**  
Easily couple and uncouple attachments with hydraulic additional function

5050 - 5065T



### Powerflow\*

The machines can be equipped with various hydraulic attachments for the many areas of application and industry, and become true multi-functional talents.

No matter what the job at hand is, or whether used with a rotary sweeper, snow blower, mulcher or plate compactor, the Kramer wheel loaders are applicable during all four seasons.

\* not for the 5050



Concept solution for system bearer	5050	5055	5065	5065T
3rd control circuit [l/min]*	56	56	56	56
Power flow performance hydraulics [l/min]*	-	90	90	90

\*max. pump values

### High-speed gearbox - stepless up to 30 km/h

Optimal prerequisites provide the stepless hydrostat high-speed gearbox up to 30 km/h. This gives the wheel loader both optimal tractive force and a lower diesel consumption.

The high-speed gears are used for movement on straights and on roads.



### Three loader units

Depending on requirements there are up to three different loader units available. The standard and optional extended loader unit are both parallel-guided and ensure a consistent lift capacity as well as a safe operation during materials handling.

#### Standard loader unit (P-kinematics)



The parallel-guided loader unit ensures constant lift capacity and a safe operation in materials handling. Due to the tilt back angle of up to 45° and the tilt-out angle of up to 45°, the wheel loader does not lose any material in bucket application, even when it is very full, allowing for a complete emptying of the bucket.

- Precise and safe working possible
- High tear-out forces
- Precise parallel guidance over the entire lift height

#### Extended loader unit (P-kinematics)



Specific customer wishes can be met even more flexibly due to the extended loader unit. Among other things, the range, payload and lift height change compared to the standard loader unit.

- Optimal view of the quickhitch facility and the attachment
- Increased lift height
- Extension of the loader unit by 190 mm (5055, 5065)

#### Telehandler system (Z-kinematics)



The view of the attachment is exceptional thanks to the compact modular design of the telehandler system. The advantages of Z-kinematics: in the case of equal size cylinders, dumping in a bucket creates a higher tearout force since pressure is applied to the piston side of the hydraulic cylinder when filling the bucket.

- High tear-out forces
- Good view of the quick coupler system and the attachment
- Additional load-over and stacking height, as well as reach and dumping width

# Machine highlights of the 5050 - 5065T

Sturdy on the outside and intelligent on the inside



**Reduced operating costs**  
through optimum power to weight ratio and compact dimensions.

**More reach and lift height**  
due to a telescoping loader unit.

**Fatigue-free work**  
thanks to the spacious and ergonomic cabin, which is installed as a standard (5065) or optionally.

**Gentle retraction and extension**  
thanks to the final position dampening in the retract and extension.

**High reliability**  
through easily accessible maintenance points and time-tested and proven components.

**Flexible in application**  
with a 3rd control circuit, depressurised return flow with drain line and front outlet.

**Smart Ballast (5050)**  
easily and quickly adjust the payload and weight of the machine.

**High bucket apron, long bucket bottom as well as a large tilt in and tilt back angle** for a safe and quick material transport with high volumetric efficiency.

**Variable drive system** - with two types of steering (all-wheel steering and optional front wheel steering) and a travel speed of up to 30 km/h. Furthermore, there are two travel speed settings.

**The hydraulically activated quickhitch facility** makes the Kramer an all-rounder in seconds without leaving the operator's seat. Efficient work with a parallel-guided loader unit with P-kinematics for wheel loaders and with Z-kinematics for the telescopic wheel loader.

**Excellent traction**  
thanks to 100% connectible differential lock in the front axle for 5065 and 5065T (option for 5050, 5055) and the variety of tyre options.

**Wide and safe entry**  
thanks to the undivided chassis with all-wheel steering.

ON THE SAFE SIDE

# A variety of tasks











## Always the right attachments

Regardless of what challenges your application holds for you: with the different attachments, you will always have a handle on the situation. Thanks to the hydraulic quickhitch system, you can adapt your Kramer wheel loader to any situation in no time. Standard attachments can even be changed in less than 10 seconds.

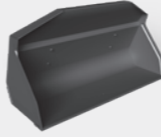
The attachment is based on your needs. You can find out more about our attachments at: [www.kramer.de/attachments](http://www.kramer.de/attachments)

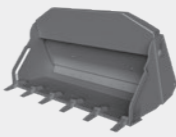
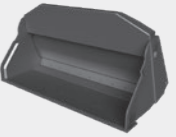

# Product range of attachments

			
Pallet fork	Pallet forks fold-down	Pallet forks hydraulic parallel adjustment	Standard bucket with rip-out teeth
			
Standard bucket without rip-out teeth	Standard bucket without rip-out teeth with screwed-on blade	Power grab bucket with rip-out teeth	Power grab bucket without rip-out teeth
			
Side swing bucket	Snowplough model A	Snowplough model B	Salt spreader

Exact specifications and availabilities of attachments vary by model and country. Your competent Kramer dealer will be happy to help you.

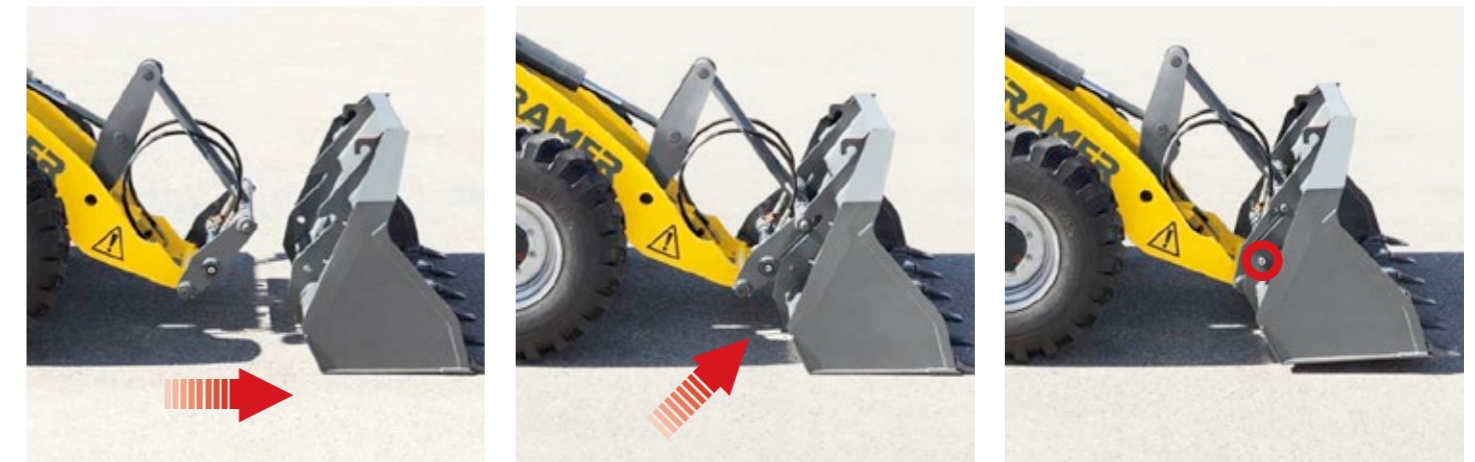

**Hydraulic quick-change system - The Kramer quickhitch system:** approach the attachment, pick up the attachment hydraulically from the operator's seat and lock it using the touch slide on the joystick. The lock cylinder is located outside of the pivot point of the quickhitch plate and is thus not in the contamination area.

# Tyre product range



- Good self-cleaning
- Good flank protection
- High running performance

**Universal tread - BKT**  
5035, 5040



- High running performance
- High level of traction
- Good mobility on soft ground
- Good self-cleaning

**Construction machine tread - Mitas**  
5035, 5040



- good track guiding
- high level of driving safety
- Good self-cleaning
- High running performance

**Traction tread - Mitas**  
5035, 5040



- Good self-cleaning
- Good lateral stability
- High running performance, especially when used on hard and aggressive substrates
- High level of traction

**Industrial tread - Michelin**  
5035, 5040



- Good winter serviceability
- High running performance
- Noise-optimised
- For applications on and off the road

**Municipal tread - Continental**  
5035, 5040



- High running performance
- Good self-cleaning
- Good mobility on soft ground
- High level of traction

**Universal tread - Alliance**  
5050 - 5065T



- High lift capacity
- High level of traction
- Excellent stability and improved operating comfort
- High level of running smoothness

**Multi-purpose tread - Michelin**  
5050 - 5065T



- Good resistance
- Smooth running on the road
- High level of traction
- For applications on and off the road

**Multi-purpose tread - Mitas**  
5050 - 5065T



- Good self-cleaning
- Ideal for loamy ground
- High level of traction
- Smooth running on the road

**Traction tread - Mitas Premium**  
5050 - 5065T



- Smooth running on the road
- Good resistance
- Well-suited in sand and gravel

**Municipal tread - Alliance**  
5050 - 5065T



- High level of traction
- Well-suited in sand and gravel
- Good resistance

**Municipal tread - Nokian**  
5050 - 5065T

Choosing the right tyres is crucial when it comes to using your wheel loader. Exact tyre specifications and availabilities vary by model and country. Your competent Kramer dealer will be happy to help you.



# EquipCare - telematics

## All the information in one glance

Always a step ahead, because EquipCare provides data, facts and answers to questions: Where is my machine right now, when is maintenance due and when does it make economic sense to replace wear parts? This helps you to avoid downtime and to extend the service life of your machine.

### How does it work?

EquipCare is installed as standard on all Kramer vehicles. It contains a telematics module, which collects data from the machines and sends it to the manager or app via a cloud. Here, as the Equipcare user, you can view and assess the data.

The EquipCare Manager is the main portal for the telematics data of your vehicles and is controlled via the computer. The EquipCare app is for mobile access and keeps you informed about everything immediately, no matter where you are.

### Your benefits:

Thanks to EquipCare, we always know where your machine is located currently. If the machine leaves a previously defined geo-zone, you will receive a notification on your smartphone or your computer. All events are shown here in detail, from the error message to the maintenance performed. All unnecessary downtime is avoided and the operating duration is precisely recorded.

The machine has recognised a problem? Notify your dealer of this on-site directly via the app and an initial remote diagnosis can be performed. Thanks to the proactive communication of your machine, you will be promptly informed about everything.

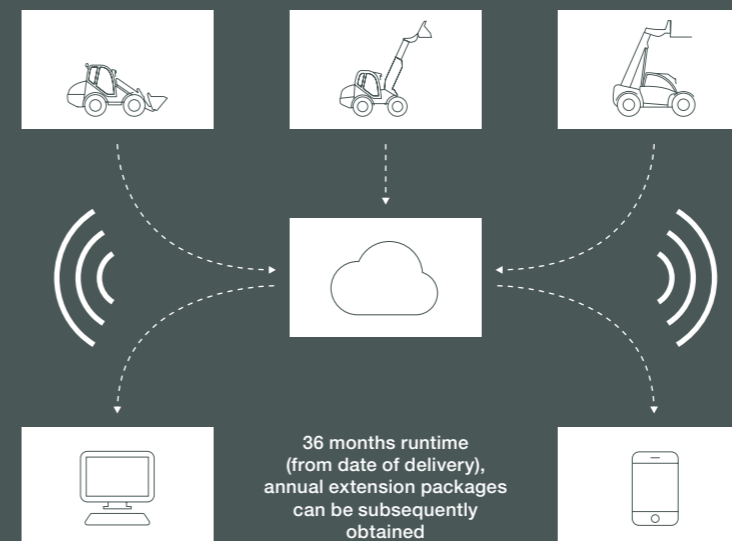

You can find more information at:  
[www.kramer.de/equipcare](http://www.kramer.de/equipcare)

SEARCH NOW!



# EQUIPCARE

The telematics portals are accessible for you around the clock:



**EquipCare Manager:** The precise position or the GPS data of your machines can be viewed at any time in your password-protected area.

[www.kramer.de/equipcarelogin](http://www.kramer.de/equipcarelogin)

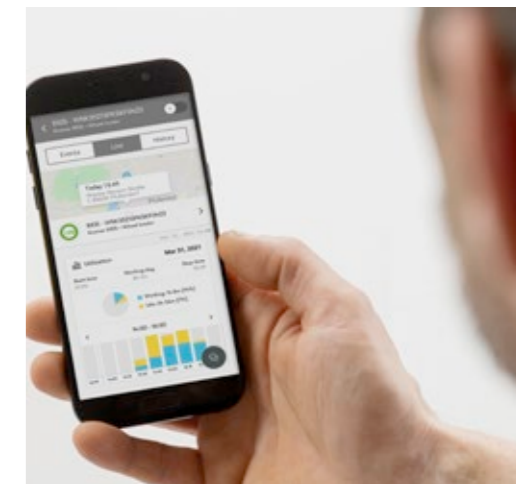

**EquipCare App:** The app provides you with a number of functions to access your machine data and information while on the go. Simply download and install the app from the Google Play Store or the Apple App Store.

◀ Go to the app



# Top Performance

---

## Dimensions and power to weight ratio

- perfect ratio between payload and operating weight
- easy transport on 3.5 t trailers (5035, 5040, 5050)
- economic use that saves time and fuel thanks to the small turning radius
- economic power to weight ratio

---

## Engines

- high torque and economical engines by Yanmar
- the latest exhaust emissions after-treatment with DOC + DPF
- newest engine technology with exhaust emission stage V

---

## Wheel loaders 5035 and 5040

- powerful lift capacity: 5035 - 11.5 kN, 5040 - 15.8 kN
- spacious cabin with very good all-round visibility and a variety of options
- three types of steering for maximum flexibility
- Smart Driving PRO with the option of three operating modes for the 5040
- low-cabin available optionally as canopy or cabin version

---

## Wheel loader 5050

- powerful lift capacity of 37 kN
- perfect performance characteristics of 34.3 kW / 46 hp
- optimal transport weight of 2,685 kg incl. cabin
- high bucket pivotal point of 2,840 mm
- flexible Smart Ballast weights of a total of 100 kg

---

## Telescopic wheel loader 5065T

- extra 50% lift height and dumping height
- extra 42% stacking height
- extra 38% load-over height

e.g. for storing materials, stacking pallets, filling high-walled lorries, trailers or containers

# Technical Data

Engine	Unit	5035	5040	5050	5055	5065	5065T
<b>Make</b>	–	Yanmar	Yanmar	Yanmar	Yanmar	Yanmar	Yanmar
<b>Type/Model</b>	–	3TNV82A	3TNV86CT	4TNV88C	4TNV88C (standard) 4TNV86CT (option)	4TNV88C (standard) 4TNV86CT (option)	4TNV88C (standard) 4TNV86CT (option)
<b>Output</b>	<b>kW</b>	18.5	28.5	34.3	34.3 (standard) 41.1 (option)	34.3 (standard) 41.1 (option)	34.3 (standard) 41.1 (option)
<b>Max. torque</b>	<b>Nm at rpm</b>	85.5 at 1,200	132.2 at 1,690	140.4 at 1,820	140.4 at 1,820 167 at 1,820 (option)	140.4 at 1,820 167 at 1,820 (option)	140.4 at 1,820 167 at 1,820 (option)
<b>Displacement</b>	<b>cm<sup>3</sup></b>	1,331	1,568	2,190	2,190 (standard) 2,091 (option)	2,190 (standard) 2,091 (option)	2,190 (standard) 2,091 (option)
<b>Exhaust emission stage</b>	–	EU level V	EU level V	EU level V	EU level V	EU level V	EU level V
<b>Power transmission</b>	<b>Unit</b>						
<b>Drive</b>	–	Variable, hydrostatic drive system					
<b>Travel speed</b>	<b>km/h</b>	20	30	20 (standard) 30 (option)	20 (standard) 30 (option)	20 (standard) 30 (option)	20 (standard) 30 (option)
<b>Axles</b>	–	Axle carrier made of cast steel with wheel hub motors		Planetary steering axle	Planetary steering axle	Planetary steering axle	Planetary steering axle
<b>Total oscillation angle</b>	°	7	7	8	8	8	8
<b>Differential lock</b>	%	Compensation differential hydraulic (option)	Compensation differential hydraulic (option)	100% (option FA)	100% (option FA)	100% front axle	100% front axle
<b>Service brake</b>	–	Hydrostatically	Hydrostatically	Hydr. disc brake		Hydr. disc brake	
<b>Parking brake</b>	–	Spring-loaded multi-plate braking system, electro-hydraulically controlled to HA		Mech. disc brake		Mech. disc brake	
<b>Standard tyres</b>	–	27x10.5-15	27x10.5-15	10.5-18	10.5-18	12.0-18	12.0-18
<b>Steering and work hydraulics</b>	<b>Unit</b>						
<b>Steering system functionality</b>	–	Hydrostatic all-wheel steering with emergency steering properties					
		Front-wheel-drive and crab steering (option)			Front wheel steering (option)		
<b>Functioning of work hydraulics</b>	–	Gear pump					
<b>Steering cylinder</b>	–	Double-acting with independent final position synchronization					
<b>Steering lock max.</b>	°	38	38	38	38	38	38
<b>Max. flow rate of pump</b>	<b>l/min</b>	20	30	56	56	56	56
<b>Max. pumping capacity optional</b>	<b>l/min</b>	-	56	-	90	90	90
<b>Max. pressure</b>	<b>bar</b>	240	240	240	240	240	240
<b>Quickhitch system</b>	–	HV/WL - S			HV/WL - C		
<b>Pilot operation</b>	–	Hydraulic					
<b>Pilot control of 3rd control circuit</b>	–	Electrical					

# Technical Data

Kinematics	Unit	5035	5040	5050	5055	5065	5065T
<b>Design system</b>	–	Z-kinematics	Z-kinematics	P-kinematics	P-kinematics	P-kinematics	Z-kinematics
<b>Lifting force calculation as per ISO 14397-2 hydraulic</b>	<b>kN</b>	11.5	15.8	37	32.5	32.5	32.5
<b>Tearout force calculation as per ISO 14397-2</b>	<b>kN</b>	12.2	13.3	31.7	28	28	28
<b>Lift cylinder raising/lowering</b>	<b>s</b>	6.0/4.5	6.0/4.5	4.6/2.9	4.8/3.2	4.8/3.2	6.7/5.0
<b>Tilt in/tilt out tilt cylinder: (upper position of the loader unit)</b>	<b>s</b>	2.4/3.3	2.2/2.4	2.6/3.1	2.1/2.0	2.1/2.0	3.5/3.0
<b>Tilt-in / tilt-out angle</b>	°	43/40	43/40	45/40	43/45	43/45	30/40
<b>Bucket tipping load</b>	<b>kg</b>	1,200	1,400	1,800	1,980	2,340	2,500
<b>Stacking payload S=1.25</b>	<b>kg</b>	750	900	1,200 (1,360)*	1,600	1,750	1,650
<b>Capacities</b>	<b>Unit</b>						
<b>Fuel tank</b>	<b>l</b>	48	48	60	60	60	60
<b>Hydraulic oil tank</b>	<b>l</b>	40	40	58	58	58	58
<b>Electrical system</b>	<b>Unit</b>						
<b>Operating voltage</b>	<b>V</b>	12	12	12	12	12	12
<b>Battery / alternator</b>	<b>Ah/A</b>	74/55	74/55	74/80	74/80	74/80	74/80
<b>Starter motor</b>	<b>kW</b>	1.7	1.7	2.3	2.3	2.3	2.3
<b>Noise emissions**</b>	<b>Unit</b>						
<b>Measured value</b>	<b>dB(A)</b>	99	99	100.3	100.3	100.3	100.3
<b>Guaranteed value</b>	<b>dB(A)</b>	101	101	101	101	101	101
<b>Noise level at the operator's ear</b>	<b>dB(A)</b>	80	80	79	79	79	79
<b>Vibrations***</b>	<b>Unit</b>						
<b>Vibration total value of the upper extremities of the body</b>	<b>m/s<sup>2</sup></b>	< 2.5 m/s <sup>2</sup> (< 8.2 feet/s <sup>2</sup> )					
<b>Maximum weighted average effective value of acceleration for the body</b>	<b>m/s<sup>2</sup></b>	< 0.5 m/s <sup>2</sup> (< 1.64 feet/s <sup>2</sup> )**** 1.28 m/s <sup>2</sup> (4.19 feet/s <sup>2</sup> )*****					

\* with Smart Ballast (8 x 12.5 kg)

\*\* Information: The measurement occurs as per the requirements of the standard EN 474 and the directive 2000/14/EC. Measuring station: Paved surface.

\*\*\* Uncertainties of measurement as specified in ISO/TR 25398:2006. Please instruct or inform the operator of possible dangers caused by vibrations.

\*\*\*\* On flat and solid ground with the corresponding driving style



\*\*\*\*\* Application in extraction under harsh environmental conditions

## Technical Data

5035: Standard loader unit	Unit	Standard bucket with rip-out teeth	Standard bucket without rip-out teeth	Power grab bucket with rip-out teeth	Power grab bucket without rip-out teeth
					
Bucket capacity	m <sup>3</sup>	0.35	0.35	0.23	0.23
Material density	t/m <sup>3</sup>	1.80	1.80	1.80	1.80
Overall length of attachment	mm	780	685	774	678
Total vehicle length without attachment	mm	3,460	3,460	3,460	3,460
Total vehicle length with attachment tilted max. 200 mm above ground	mm	4,050	3,980	4,090	4,020
Bucket width	mm	1,250	1,250	1,250	1,250
Bucket swivel point	mm	2,800	2,800	2,800	2,800
Load-over height	mm	2,680	2,680	2,600	2,600
Dumping height	mm	2,290	2,290	2,240	2,240
Dump reach	mm	260	260	200	200
Scraping depth	mm	60	60	140	140
Weight of attachment	kg	113	109	156	151

\* basic equipment with cabin and attachment

## Technical Data

5040: Standard loader unit	Unit	Standard bucket with rip-out teeth	Standard bucket without rip-out teeth	Power grab bucket with rip-out teeth	Power grab bucket without rip-out teeth
					
Bucket capacity	m <sup>3</sup>	0.36	0.36	0.23	0.23
Material density	t/m <sup>3</sup>	1.80	1.80	1.80	1.80
Overall length of attachment	mm	829	753	677	773
Total vehicle length without attachment	mm	3,460	3,460	3,460	3,460
Total vehicle length with attachment tilted max. 200 mm above ground	mm	4,090	4,040	4,090	4,020
Bucket width	mm	1,400	1,400	1,400	1,400
Bucket swivel point	mm	2,800	2,800	2,800	2,800
Load-over height	mm	2,680	2,670	2,600	2,600
Dumping height	mm	2,260	2,240	2,240	2,240
Dump reach	mm	290	300	200	200
Scraping depth	mm	60	70	140	140
Weight of attachment	kg	129	137	189	183

\* basic equipment with cabin and attachment

# Dimensions

Side view

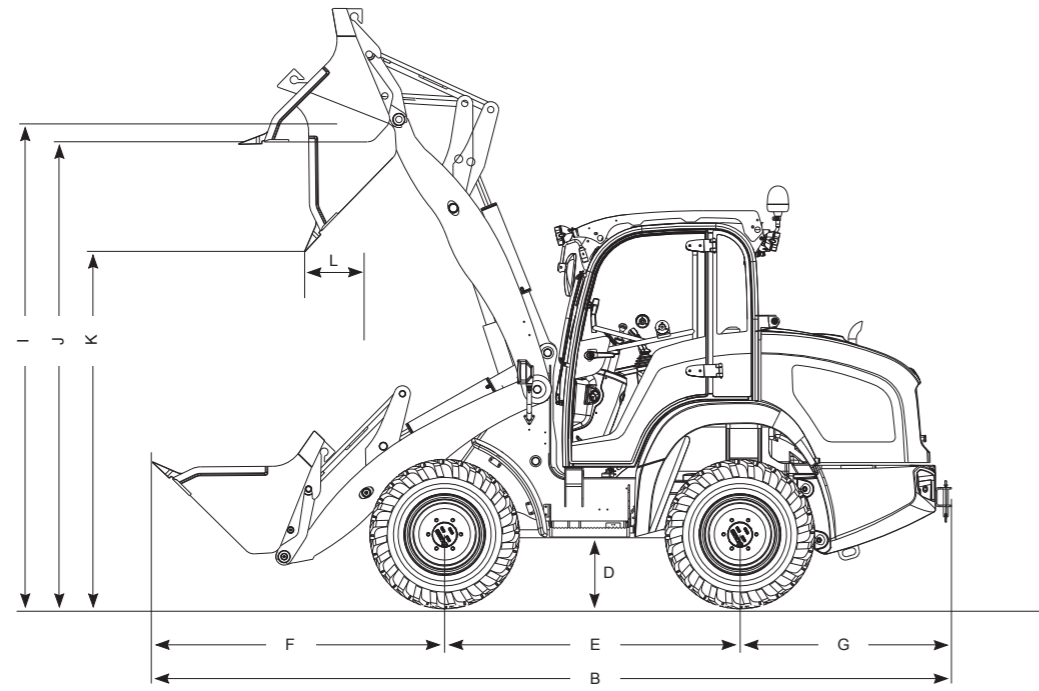

Front view

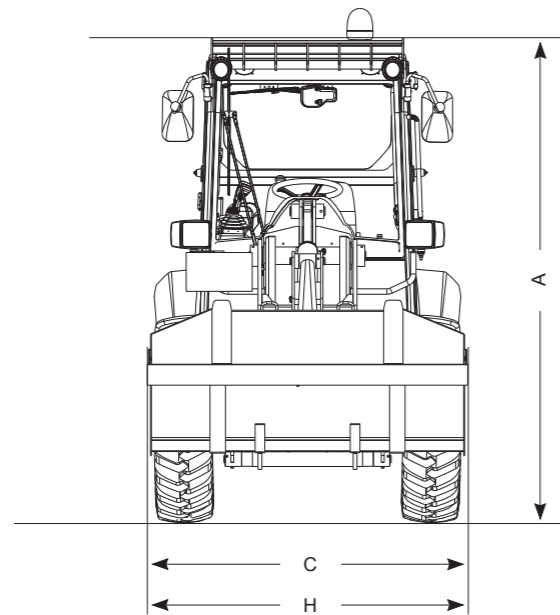

# Dimensions

Standard equipment with standard bucket		Unit	5035	5040	5050	5055	5065	5065T
A	Height*	mm	2,170 (standard) 2,020 (option)	2,170 (standard) 2,020 (option)	2,390	2,390	2,390	2,470
B	Length	mm	4,050	4,090	4,790	4,950	4,950	5,350
C	Width*	mm	1,260	1,260	1,590	1,590	1,595	1,595
D	Ground clearance	mm	220	290	280	280	280	280
E	Wheel base	mm	1,525	1,525	1,850	1,850	1,850	2,000
F	Centre of front axle to tip of teeth	mm	1,390	1,430	1,620	1,780	1,780	1,992
G	Centre of rear axle to end of vehicle	mm	1,140	1,140	1,320	1,320	1,320	1,320
H	Bucket width	mm	1,250	1,400	1,650	1,650	1,650	1,650
I	Bucket swivel point	mm	2,800	2,800	2,840	3,050	3,050	4,270
J	Load-over height	mm	2,680	2,680	2,610	2,890	2,900	4,010
K	Dumping height	mm	2,180	2,140	2,080	2,320	2,330	3,500
L	Dump reach	mm	260	290	270	315	315	810
-	Stacking height	mm	2,630	2,630	2,600	2,950	2,950	4,030
-	Turning radius (over tires)	mm	2,000	2,000	2,700	2,700	2,700	2,900

Standard equipment with standard bucket		Unit	5055L	5065L
A	Height*	mm	2,390	2,390
B	Length	mm	5,140	5,140
C	Width*	mm	1,590	1,595
D	Ground clearance	mm	280	280
E	Wheel base	mm	1,850	1,850
F	Centre of front axle to tip of teeth	mm	1,970	1,970
G	Centre of rear axle to end of vehicle	mm	1,320	1,320
H	Bucket width	mm	1,650	1,650
I	Bucket swivel point	mm	3,300	3,300
J	Load-over height	mm	3,150	3,150
K	Dumping height	mm	2,650	2,650
L	Dump reach	mm	410	410
-	Stacking height	mm	3,200	3,200
-	Turning radius (over tires)	mm	2,700	2,700

\*with standard tyres

## Load-bearing capacity diagram

### Load hook

**A** (with tilted quickhitch facility)

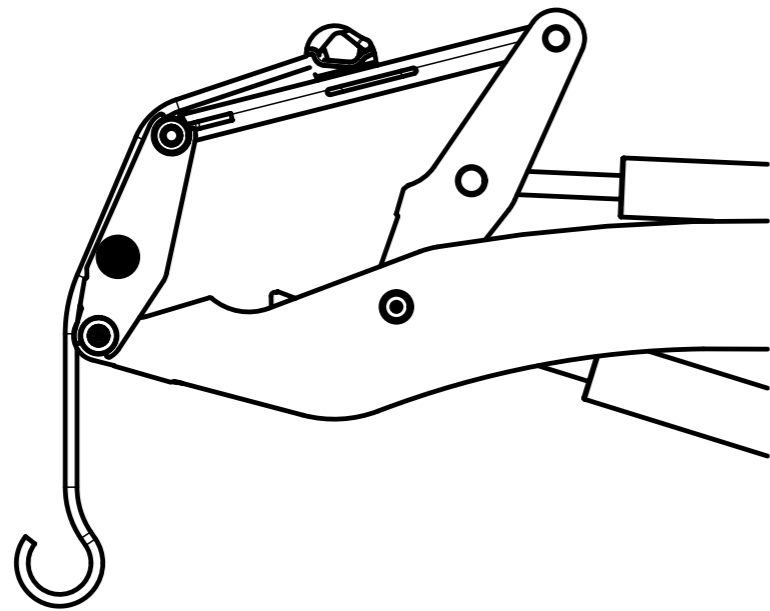

Load hook on rocker arm		Unit	5035	5040
A	Payload for elongated loader unit and tilted quickhitch facility	kg	750	900

## Load-bearing capacity diagram

### Load hook

**B** (with emptied quickhitch facility)

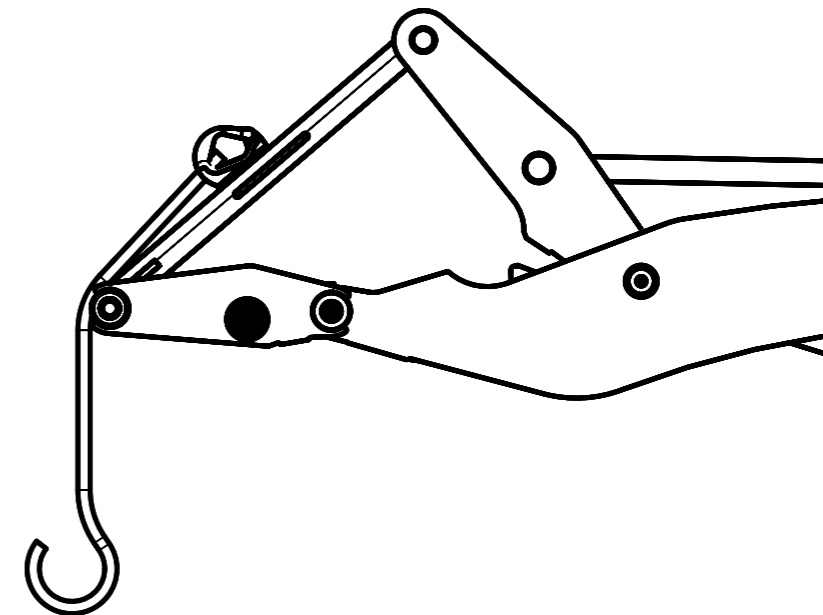

Load hook on rocker arm		Unit	5035	5040
B	Payload for elongated loader unit and emptied quickhitch facility	kg	600	750

# Load-bearing capacity diagram

5065T (with cabin)

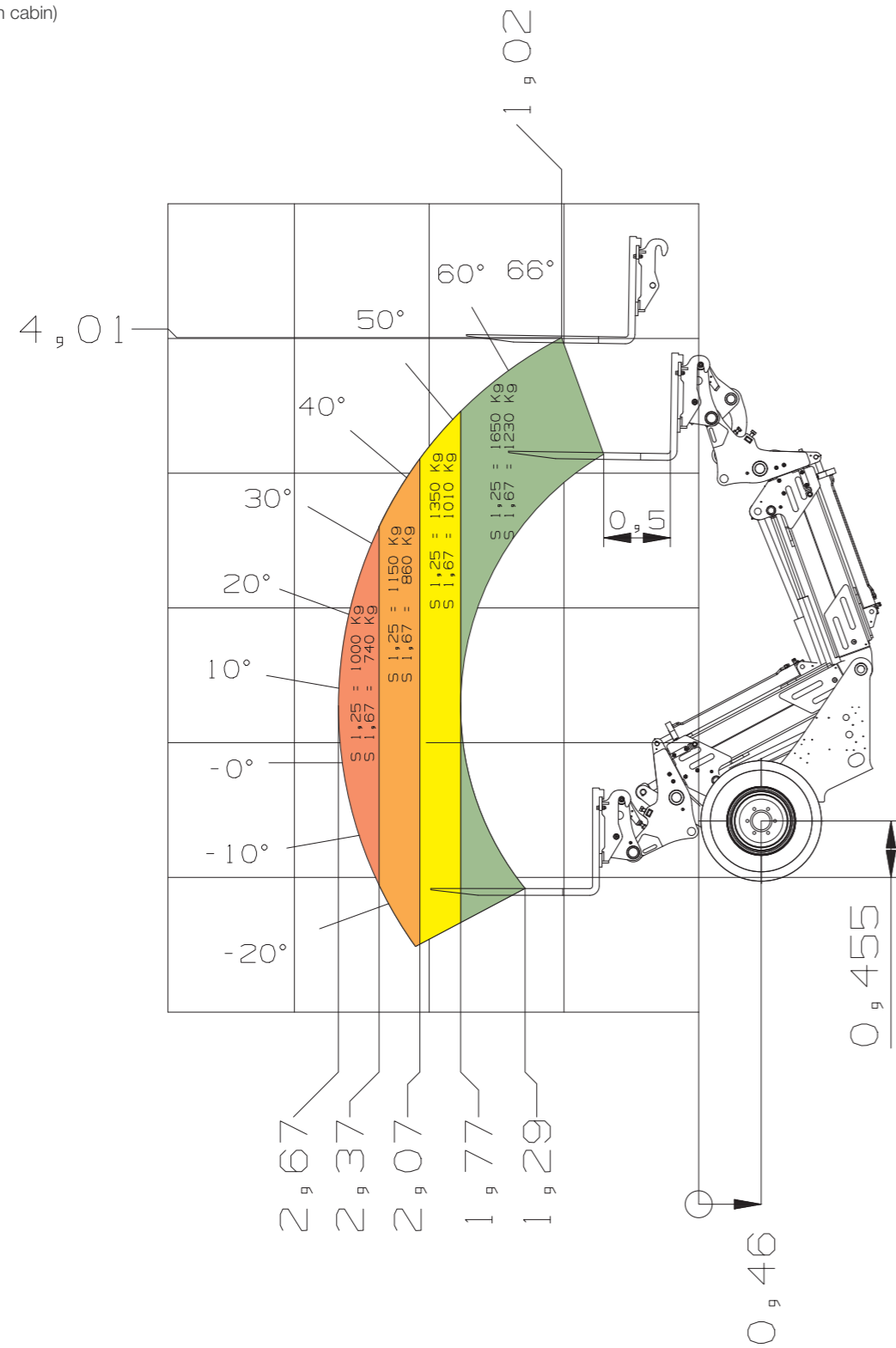

# Service and spare parts

Are you looking for appropriate spare parts or operating instructions for your Kramer machine? With Kramer maintenance and repair packages, there is a tailor-made spare part ready at hand for each machine. You will receive all of the required spare parts or operating instruction from our Kramer dealers. With our Kramer Dealer Locator, you can find your local dealer. Simply enter the sector, postcode or residence.

You can find more information at:  
[www.kramer.de/service](http://www.kramer.de/service)

## Maintenance, diagnosis and repair

The certified technician at your distributor will ensure that your machine is in use again as quickly as possible. You can find more information about the repair and servicing of Kramer machines on our website.



## Original Spare Parts

All spare parts that you can source from your Kramer dealer meet the strict requirements of our component manufacturers. Dimensional accuracy, performance, fit and availability can largely only be provided by the original part.



## Warranty and safety

Security 24 / Security 36 / Security 48 / Security 60: With the warranty extendible to 24, 36, 48 or even 60 months, our customers can increase their carefree period. They are protected against all eventualities by tailor-made insurance coverage. Get advice from your dealer.



## Training sessions

The Kramer Academy is the modern training centre for the service technicians of the Kramer distributors. Here the mechanics learn everything they need to know to maintain Kramer machines and learn about the constantly about the operating principles of new technical systems.





**Wheel loader**  
Bucket capacity: 0.35 - 1.80 m<sup>3</sup>



**Telescopic wheel loaders**  
Bucket capacity: 0.65 - 1.45 m<sup>3</sup>



**Telehandler**  
Payload: 1,200 - 5,500 kg

**Service that can be seen**

Focus on your daily activities – with our comprehensive services, we take care of the rest.  
We are there when you need us: capable, fast, and directly on site if necessary.



Repair & maintenance



Academy



Telematics



Insurance



Spare parts



Financial Solutions

Go to Kramer  
dealer search:  
**SCAN HERE!**



KC.EMEA.10026.V05.EN-GB