

For Earth, For Life
Kubota

RA

KUBOTA
FOUR ROTOR RAKE
PRODUCT GUIDE BOOK





Program: Four rotor rakes

The landscape for all agri businesses is continually evolving. In order to survive and prosper there is a relentless drive towards higher efficiency. Requirements are changing, with a move from smaller to larger machines. Even family farms are now investing in large four rotor rakes in order to get the best out of their forage.

Due to these challenging times, Kubota has developed a full range of four rotor rakes to fulfill the needs of our customers. Our ambition is to make the move from a two rotor machine to a four rotor rake as easy as possible.

With the two entry level models Kubota RA4012 and Andex RA4513 we offer rakes with a simple control unit. Easy to understand and allowing the operator to handle a 12.5 m working width in the same way as a twin rotor rake. For customers looking for more features we offer the Andex RA4513 Pro and Andex 1505 with ISOBUS control and load sensing hydraulics.

The following pages will help you to find the right machine and obtain more experience and knowhow about the product. If you have further questions or require a quote, feel free to contact your local Vicon team.

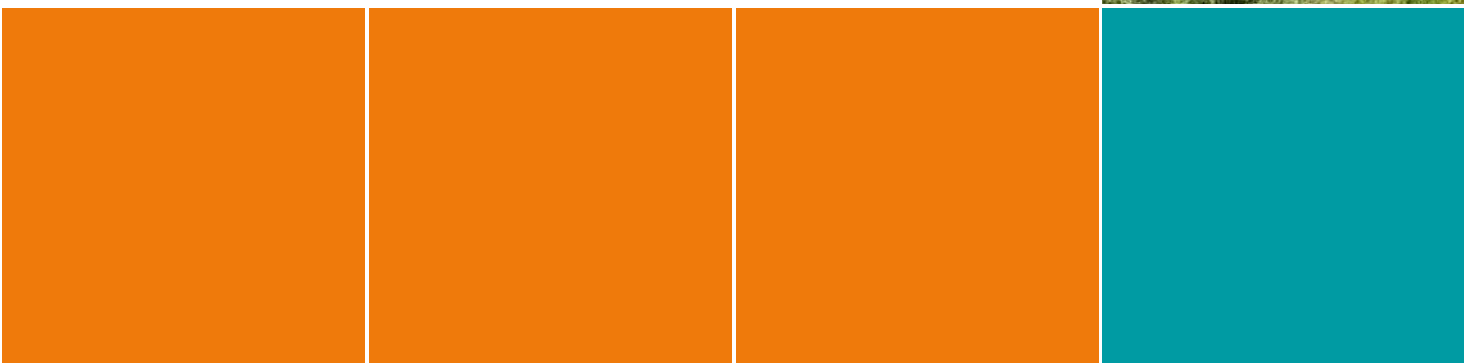





Four rotor rakes: Main customer benefits

Main customer benefits:

- Harvest in time
- Easy to use
- Maximum uptime and maintenance friendly
- Strong design with unique elements

Kubota four rotor rakes are targeted at making light work of tough and demanding operations. With impressive capacity and working widths of up to 15.0m, they incorporate straightforward design and the possibility to adjust both work and swath width, boosting the complete process of collection and pick-up, adapting to changing crop intensity during the season.

Kubota rotary rakes are designed to produce well-shaped and clean swaths, achieved by precision in every part of the rake. This gives you as customer the perfect row to get your crop harvested.





Four rotor rakes – perfect swath shape under all conditions

We are well known in the market for our perfect swath quality. We achieve this on the 15 m rake with 13 arms on the front rotors and 15 arms on the rear rotors. Both rotors rotate at the same speed. Due to this set-up the transfer of the crop package from the front rotors is not disturbed, resulting in a perfectly shaped swath.

The 12.5m rakes use a different system. On these models the rear rotor is smaller. This increases the strength and reduces the load on the arms. In addition the rear rotor rotates faster than the front rotor. With this trick the smaller machine provides fantastic capacity on the rear rotor as it is able to handle higher crop volume more easily than other competitive machines, guaranteeing a well shaped swath for following machines.

A special and outstanding feature, on all ProLine rotor machines is that you are able to adjust the cam track to fine tune the swath shape in difficult conditions. This can be useful in sensitive crops like Alfalfa, or tough heavy silage crops. Kubota rakes always adapt perfectly to the prevailing crop conditions.





CompactLine or Proline gearbox

The Kubota 12.5m 4-rotor rakes are offered with a choice of either ProLine or CompactLine Gearbox

Both machines are similar in construction. They are built up on the same frame concept. The RA4512 CompactLine version is an easy-to-use machine with substantial working width for efficient hay and medium silage use to get the best out of the drying time. It is a low cost start into the larger rake segment.

For heavy duty use, the RA4513 (Pro) machine has been developed for operation in all kind of crops. The benefits of the ProLine rotor head like the *adjustable cam track** allows complete customisation to the crop being harvested. What does this mean? For silage operations where a box shaped swath is desirable, Ideal for baler, loader wagon and chopper, which especially in heavy cuts, can be a challenge to produce it should be set to a later lifting. With hay and especially hay being made out of crops sensitive to leaf loss. For this reason the cam track can be adjusted to provide earlier lifting of the tines. The hay is not pressed against the swath and the leaves don't get broken or smashed. This allows harvest of the most important part of the plant, keeping the nutritional value high. In case of an accident the rotor is easy to repair, without disassembly of the full head.

CompactLine rotor - feature oil-immersed cam discs and guide rollers. Also, the tine arm bearings are fully lubricated, and hence absolutely maintenance-free. Both the rotor and pinion shaft are mounted on two bearings for maximum strength and long service life. The gearbox has three greasing spots. The cam track has a fixed position.

ProLine* - feature a unique drive system, which comprises an oil-immersed gearbox. The fully enclosed design and lifetime greased bearings on the tine arms ensures full and permanent lubrication, and makes the entire system absolutely maintenance-free. In case of accident each arm can be replaced individually without opening the complete rotor. The *adjustable cam track* allows perfect adaptation to the harvesting conditions.

*also used on the 15 m rake

CompactLine gearbox

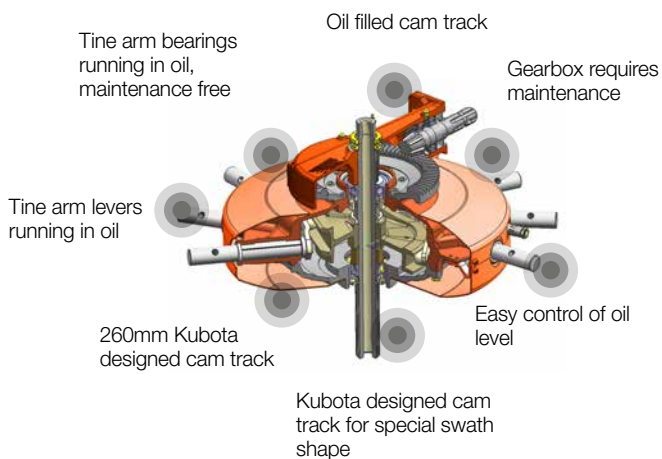

ProLine gearbox

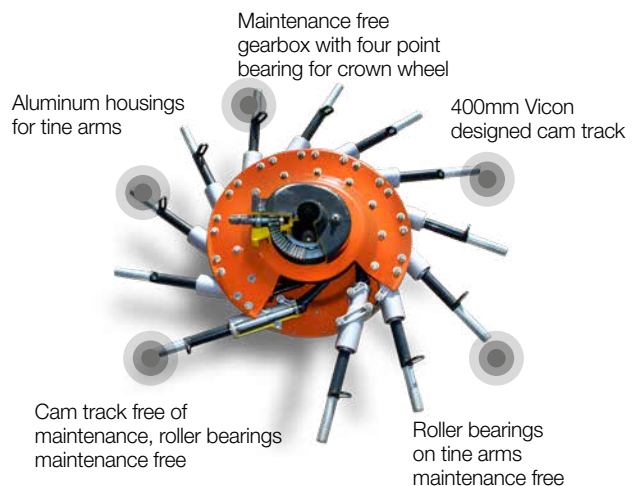



ProLine
10mm
diameter
tines.

Each tine
arm can be
dismounted
and repaired
individually.



TerraLink Quattro

Kubota TerraLink Quattro provides efficient ground contour following for each rotor, when raking grass in uneven fields.

The TerraLink Quattro system controls the rotor in 4 directions, with a unique combination of an undercarriage with 4 wheels and a specially designed rotor suspension system. This ensures superb raking performance, even at higher forward speeds. The principle behind is as well used on torsion bar suspensions known from smaller cars, car trailers and tracked vehicles. The big benefit is that the system on the rake is supporting permanent contour following also in tough conditions. Crop loss is reduced to a minimum. The partly opened frame cross section allows good flexibility.

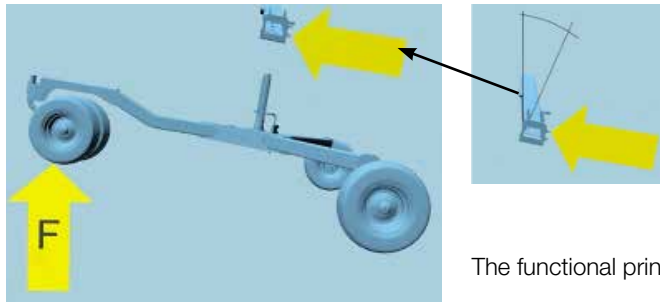

The functional principal of TerraLink





Four rotor rakes product range and product specifications



CompactLine Series
Working Width:

RA4012
10.0-12.5m



ProLine Series
Working Width:

RA4513
10-12.5m



ProLine Series
Working Width:

RA4513 Pro
10-12.5m



ProLine Series
Working Width:

RA4515
9.80-15.0m





Model	RA4012	RA4513	RA4513 Pro	RA4515
Working width (m)	10.00-12.50	10.00-12.50	10.00-12.50	9.50-15.00
Transport width (m)	2.90	2.90	2.90	2.99
Transport length (m)	8.75	8.75	8.75	9.85
Transport height (m)	3.99	3.99	3.99	3.99
Weight approx. (kg)	4400	4700	4700	6000
Theoretical capacity (ha/h)	13.8	13.8	13.8	16.5
Swath width (m)	1.20-2.20	1.20-2.20	1.20-2.20	1.40-2.40
Rotor diameter (m)	3.05/3.35	3.05/3.35	3.05/3.35	3.85
Number of arms per rotor	4x12	4x12	4x12	13 front/15 back
Power req. (kw/hp)	60/80	80/110	80/110	80/110
Wheels	500/50-17	500/50-17	500/50-17	560/60-22.5



#What are your requirements?

What are your requirements for working width and swath width?

Four rotor rakes: easily maintained

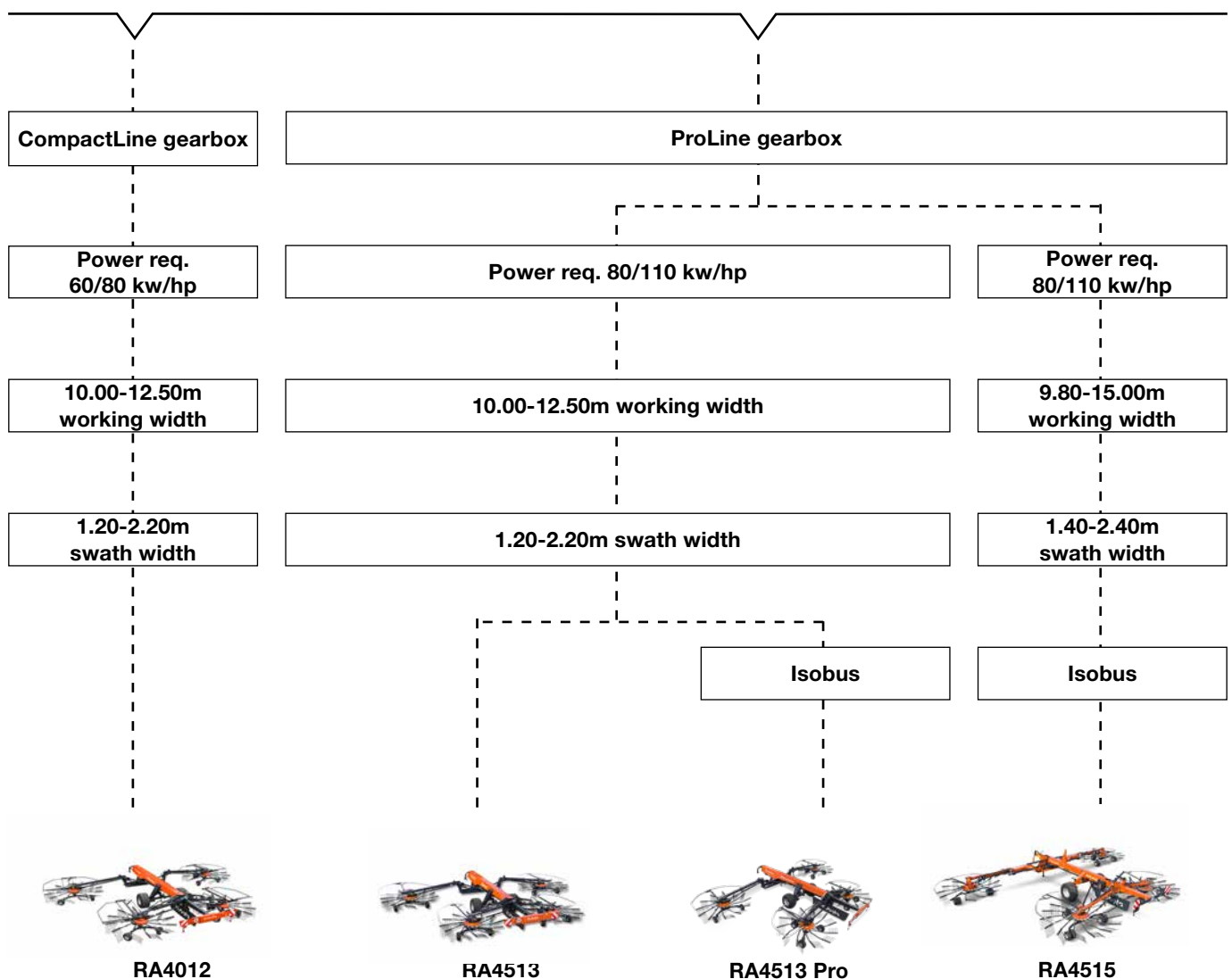



What to sell – when?



	RA4012	RA4513
WHY	<p>Ideal for farms looking for a bigger rake. Easily maintained. Comparable operation in field like a twin rotor rake. Time in front of the chopper or hay producer. Lovely fluffy even swaths.</p>	<p>Ideal for farmers and contractors, looking for a simple heavy duty rake. Easily maintained. Comparable operation in field like a twin rotor rake. Operation in front of the chopper. Heavy crop conditions. Lovely fluffy even swaths. Raking of very sensitive crops.</p>
HOW	<ul style="list-style-type: none"> • Simple control unit • No sensors on the machine • Maintenance friendly compact line rotor head • Only one single and one double acting outlet needed • Smaller rotor with higher speed at rear to create fluffy even swaths 	<ul style="list-style-type: none"> • Simple control unit • No sensors on the machine • Maintenance free rotor head • Only one single and one double acting outlet needed • Smaller rotor with higher speed at rear to create fluffy even swaths • Big tines secure a high capacity • Adjustable cam track
WHAT	<ol style="list-style-type: none"> 1. Preselection control box 2. Oil filled CompactLine rotor head 3. Terra Link 4. Difference in rotor speed and dimension prevent roping of material 5. 12 arms, 9 mm tines 	<ol style="list-style-type: none"> 1. Preselection control box 2. Maintenance free ProLine rotor head 3. Terra Link 4. Difference in rotor speed and dimension prevent roping of material at the rear 5. 12 arms, 10 mm tines



RA4513 Pro	RA4515	
<p>Ideal for advanced farmers and contractors. Easily maintained. Extended functionality for headland operations. Possibility to add electric height adjustment. Heavy crop conditions. Ideal swath shape for following machines. Raking of very sensitive crops.</p>	<p>Ideal for customers looking for an advanced high capacity rake. Easy cleaning of awkwardly shaped fields. Maximum functionality for operation. Hydraulic height adjustment. High manoeuvrability in field and on road. Overload protection for the frame. Hydraulically suspended front rotors. Protection of the grass surface. Raking of very sensitive crops.</p>	
<ul style="list-style-type: none"> • ISOBUS control • Load sensing hydraulics • Maintenance free rotor head • Choice of headland management options • Upgrade from manual height adjustment to electric possible • Smaller rotor with higher speed at rear to create fluffy even swaths • Big tines secure high capacity • Adjustable cam track 	<ul style="list-style-type: none"> • ISOBUS control • Load sensing hydraulics • Individual adjustable working width right and left • Choice of headland management options • Overload protection integrated into machine hydraulic • Hydraulic suspension adjustable in three steps • Optional hydraulic steering of transport axle • Adjustable cam track 	
<ol style="list-style-type: none"> 1. ISOBUS control 2. Maintenance free ProLine rotor head 3. Individual rotor lift 4. Transport folding at the push of a button 5. Optional electric height adjustment 6. 12 arms, 10 mm tines 	<ol style="list-style-type: none"> 1. ISOBUS control 2. Overload valve on outer arm 3. Adjustable hydraulic suspension 4. 360° free turning twin wheels on rotor 5. Optional steering transport axle 6. Individual adjustable working width 7. 13/15 arms, 10mm tines 	

Kubota RA4012 benefits

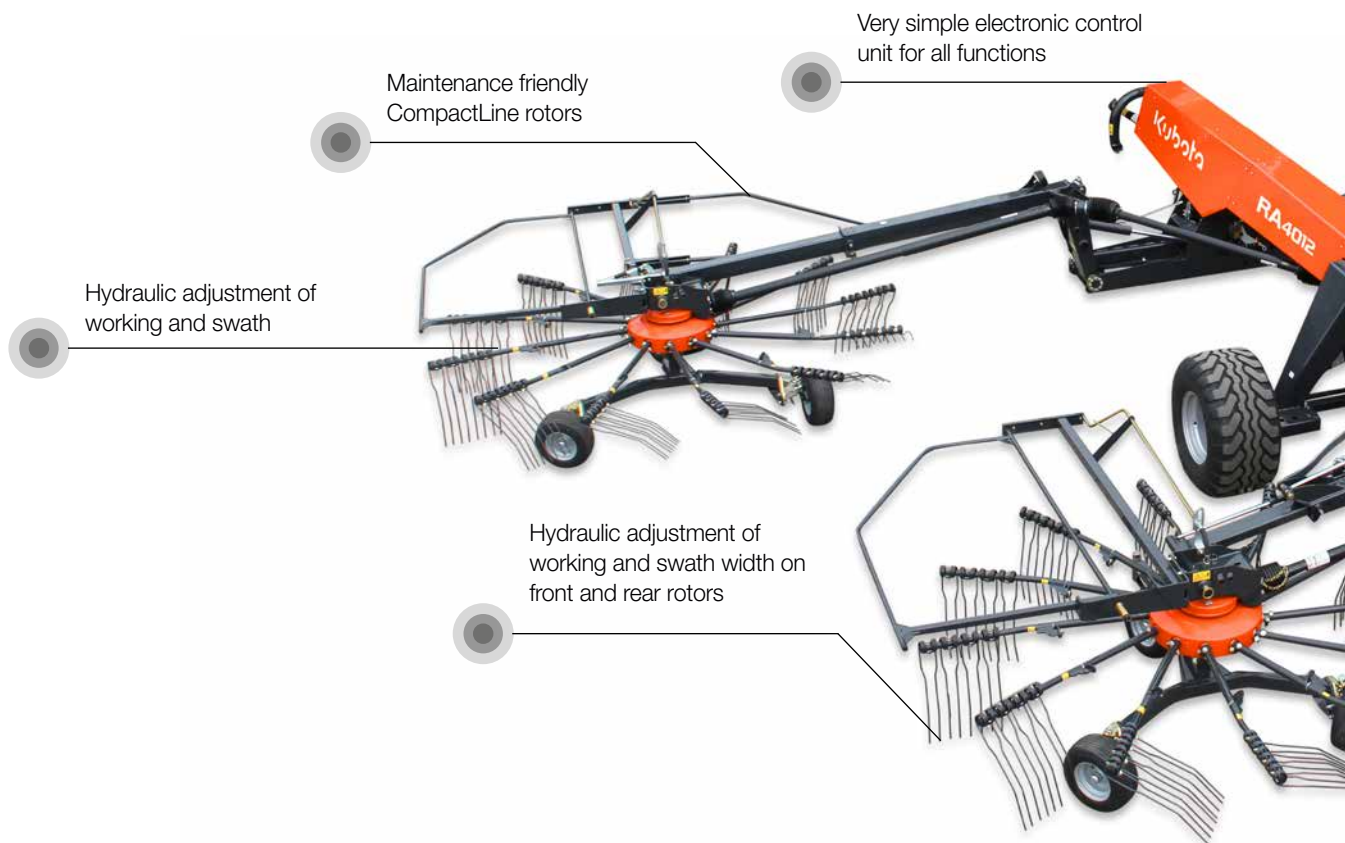

1. Swath forming

The rear rotors are smaller in diameter and turn faster. This secures the additional capacity needed on the rear rotors for the double volume, and as the speed is different it also prevents roping.



2. Tandem axle

Optional tandem axle available for front and rear rotors. The tandem axle has one fixed wheel for additional stability specially on hillsides, the other one can steer to reduce scrubbing of the grass sward in curves to a minimum.

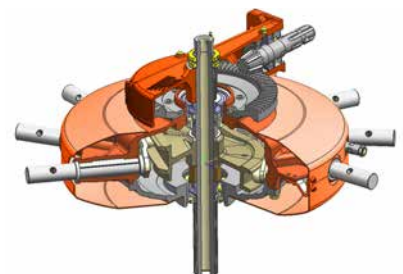

3. Rotor

The CompactLine rotor head sets the standard in this low spec segment. Only three easy to access greasing spots on each rotor make this machine outstanding in this configuration.

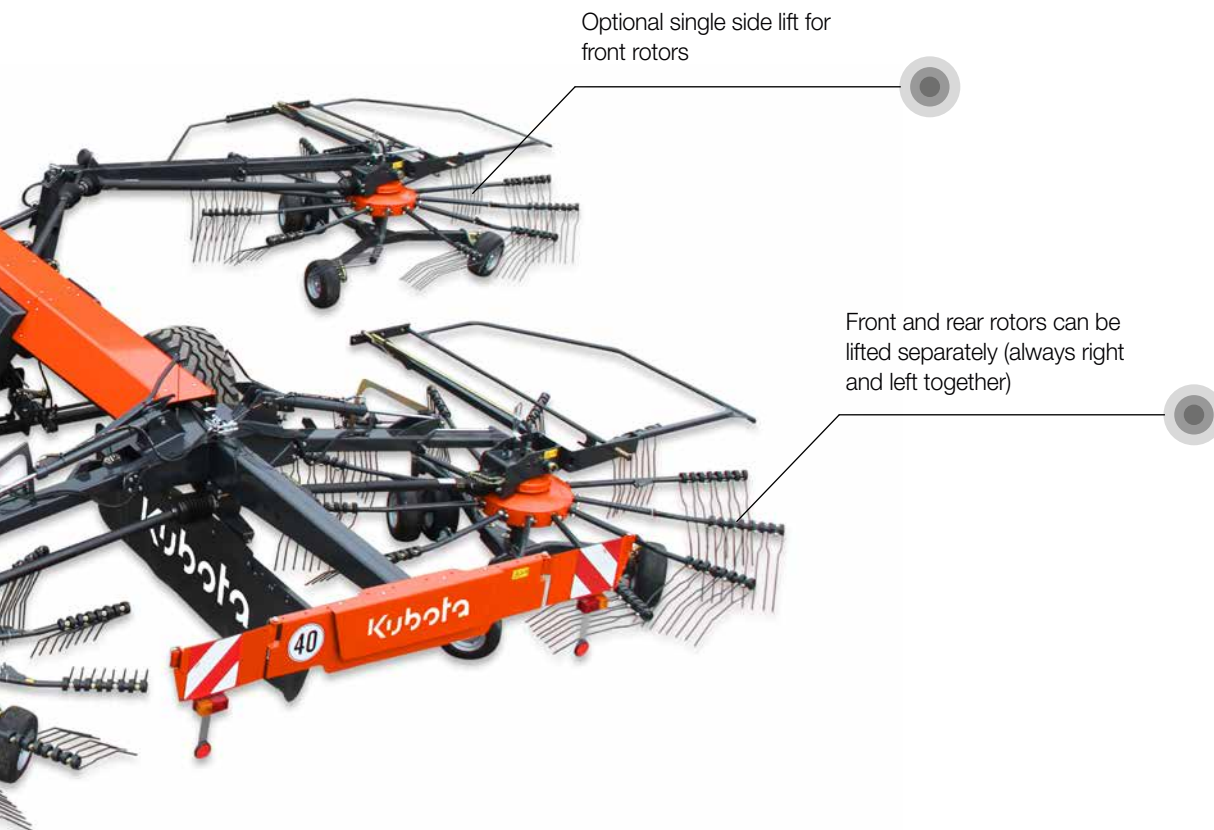

4. Ground adaptation

The maintenance-free TerraLink Quattro rotor suspension system, operating in four directions for excellent tracking, works in close combination with the four wheeled rotor to ensure high accuracy and stability on slopes. It is absolutely maintenance- and wear-free.



5. Simple control box

Simple control box for easy operation of the machine for all functions. It is available with optional individual lifting of front rotors and all functions are preselected and activated with tractor hydraulics.



6. Compact but efficient machine

Compact but efficient machine can be operated with tractors starting from 80hp. In combination with BX mower there is possibility to collect up to 20m into one swath.



#RA4513

Kubota RA4513 benefits

Front and rear rotors can be lifted separately (always right and left together)

Very simple electronic control unit for all functions

Optional single side lift for front rotors

Rear rotors have a higher turning speed to form a nice, even swath



1. Swath forming

The rear rotors are smaller in diameter and turn faster. This secures the additional capacity needed on the rear rotors for the double volume, and as the speed is different it also prevents roping.

2. Rotorhead

The maintenance-free ProLine gearbox with fully enclosed oil bath design with adjustable cam truck to cope with the largest amount of crop.

3. Hydraulic

Also the heavy duty execution operates with only one single and one double acting valve.

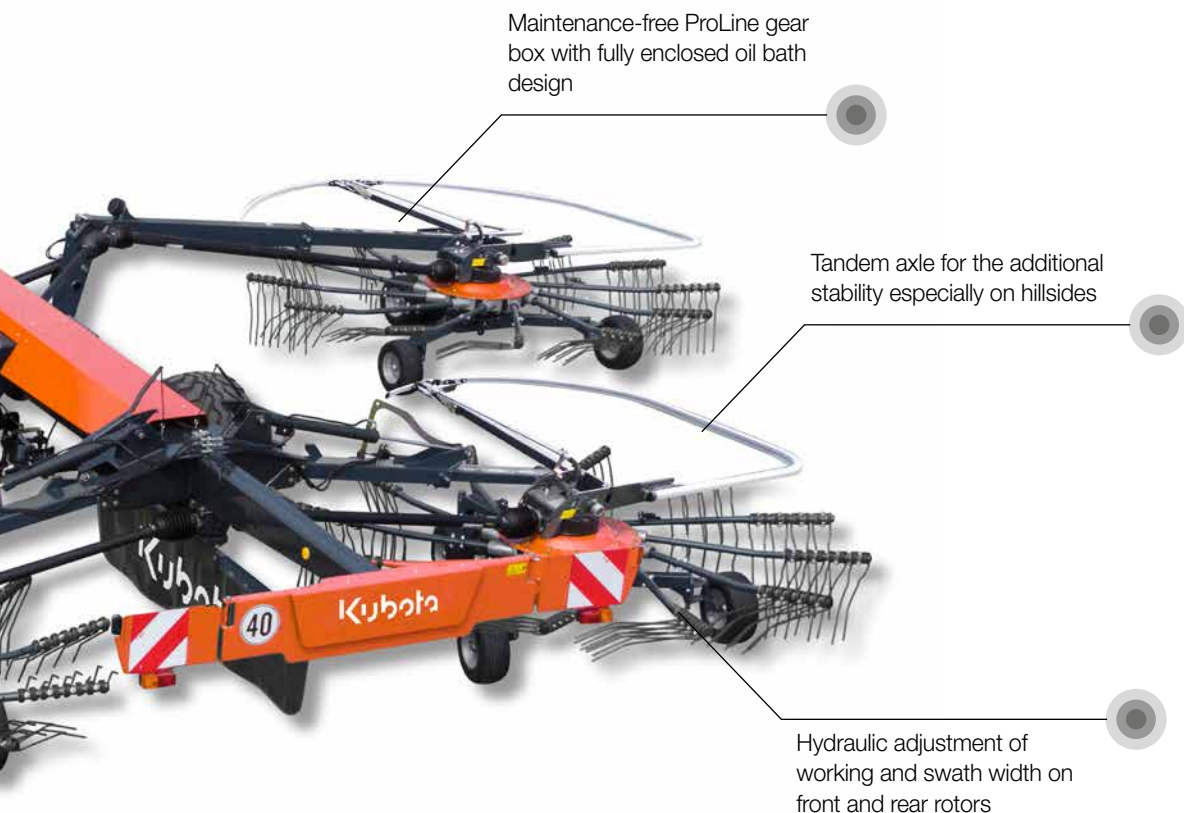

4. Tandem axle

Optional tandem axle available for front and rear rotors. The tandem axle has one fixed wheel for additional stability specially on hillside, the other one can steer to reduce scrubbing of the grass sward in curves to a minimum.



5. Simple control box

Simple control box for easy operation of the machine for all functions. It is available with optional individual lifting of front rotors and all functions are preselected and activated with tractor hydraulics.



6. Compact but efficient machine

Compact but efficient machine can be operated with tractors starting from 110hp. In combination with BX mower there is possibility to collect up to 20m into one swath.



#Easy headland mangement and transport



More uptime

Easy headland management

Four Rotor rakes come with enhanced headland management. In addition to high ground clearance of rotors during headland turns, it is possible to tailor time delay between lifting/lowering the front and rear rotors to driving speed and field conditions. This is done mechanically in an easy and uncomplicated way.

Kubota RA4012 and RA4513 will do sharp turns of up to 80°, both on headlands and during transport when passing narrow gateways. The rotors can, as a standard feature, lift pairwise which is convenient for raking also triangular shaped fields in an optimal way. Optionally the front rotors can be lifted individually.

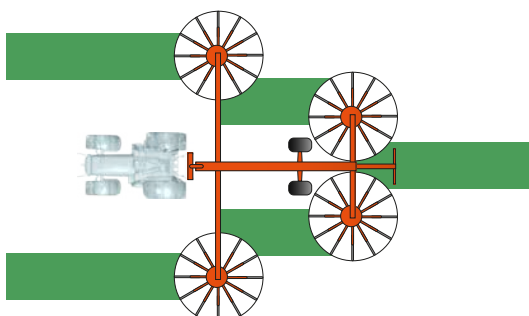

More uptime with max 4m transport height

No reasons for wasting time, not even when moving between fields. Just raise the rotors and off you go, safely below 4.00m transport height no need to leave the tractor for removing tine arms. Large transport wheels and brakes are standard. For storage all tine arms are detachable on Kubota RA4012 to allow a storage height as low as 3.40m.

A strong and stable storage foot ensures fast and trouble-free coupling and uncoupling. For Kubota RA4513 and RA4515 tine arms are generally fixed, but the top 4 are optional detachable, to reach same low storage height.



Compact but efficient machine – in combination with BX mower there is possibility to collect up to 20m into one swath.

Setting and control in comfort

Control box

All function are preselected with handheld and operated with tractor hydraulic.



Everything under Control – with ISOBUS Technology

Extended operation of the machine

The benefit of using ISOBUS control is the extended operation of the machine, starting with the folding and unfolding process or the possibility to adjust the height. Depending on the model, additional functions are integrated. In regards to comfort, it releases the customer from preselecting on the handheld and activating with the hydraulic. In combination with the standard load sensing system you just press a button and the function gets active.

Also settings can be stored and recalled

On top the ISOBUS protocol allows due to the standardised protocol the operation with tractor brand terminals and joysticks that are as well on ISOBUS. That means you don't need an additional terminal in the cabin. If the tractor is offering not the top end comfort in regards to operation due to ergonomic or other things, our terminal can be for sure added. As well if your tractor is without ISOBUS, we can deliver all needed elements.

The Isomatch Tellus Go+ is for forage machines the most recommended due to the blister buttons in addition to the touch screen. Operation without watching the screen is due to the real buttons possible. Also, our terminal can be used with other ISOBUS implements, like for example, sprayers and spreaders. Not only out of our product range, as well from competition, as long they comply to the ISOBUS standard.

To increase the comfort with the terminal further, joysticks can be added to bring the control even closer to the driver. Our joystick Isomatch Grip can be programmed and allow a fully customised interface.





#RA4513 Pro

Kubota RA4513 Pro benefits

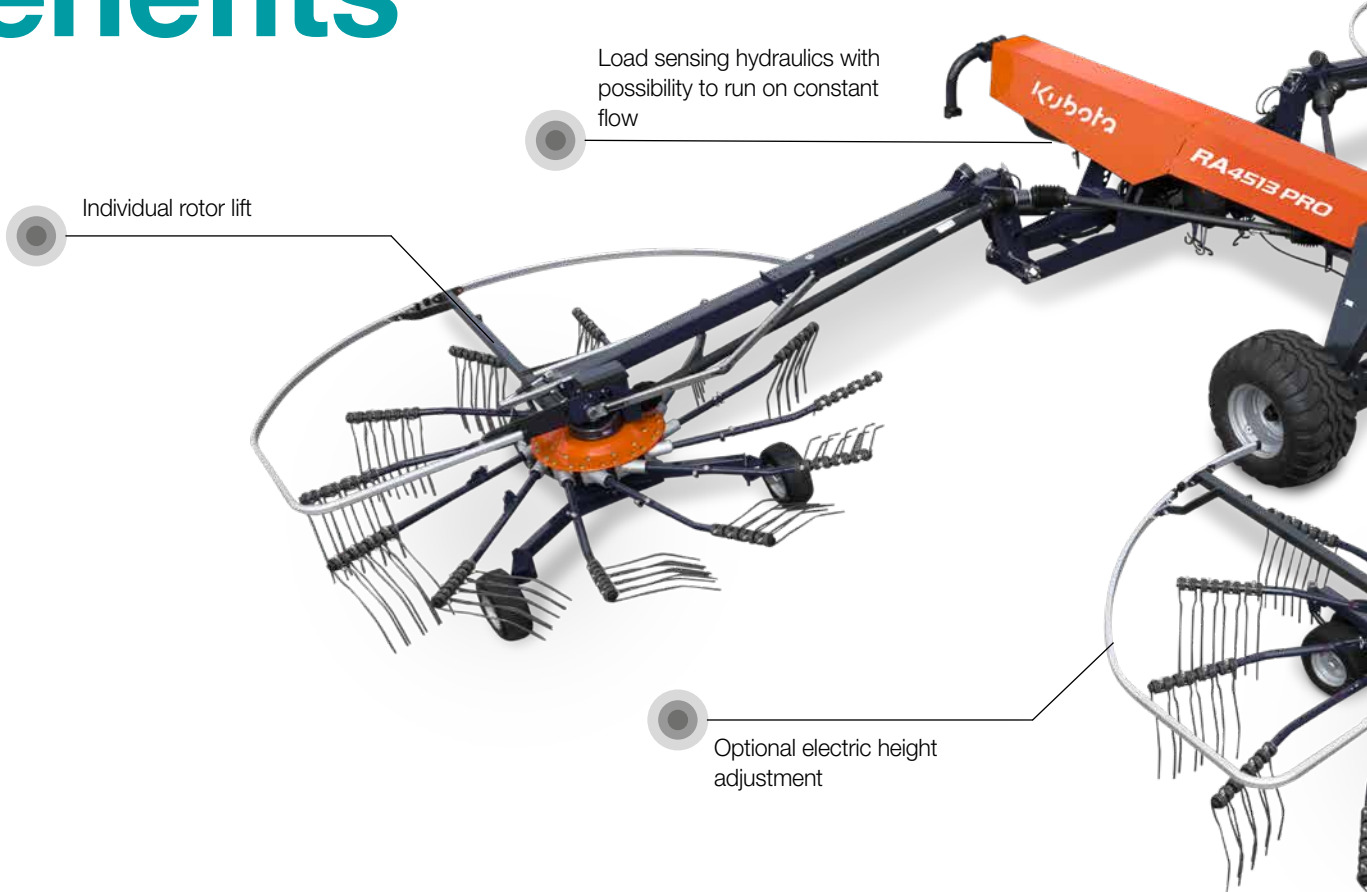

1. Swath forming

The rear rotors have a higher turning speed and they are smaller to form a nice and even swath. With BX mower up to 20m can be raked into one row.



2. Driveline

The maintenance-free ProLine rotor head is lifetime maintained. The PTO of the driveline requires maintenance only every 100 hours. Compare to hydraulic driven systems we save 24 greasing spots on the machine.



3. Hydraulic

The hydraulics are operating on load sensing. This is good for low fuel consumption compared to constant flow. If tractor is not equipped with load sensing hydraulics, constant flow is as well possible.

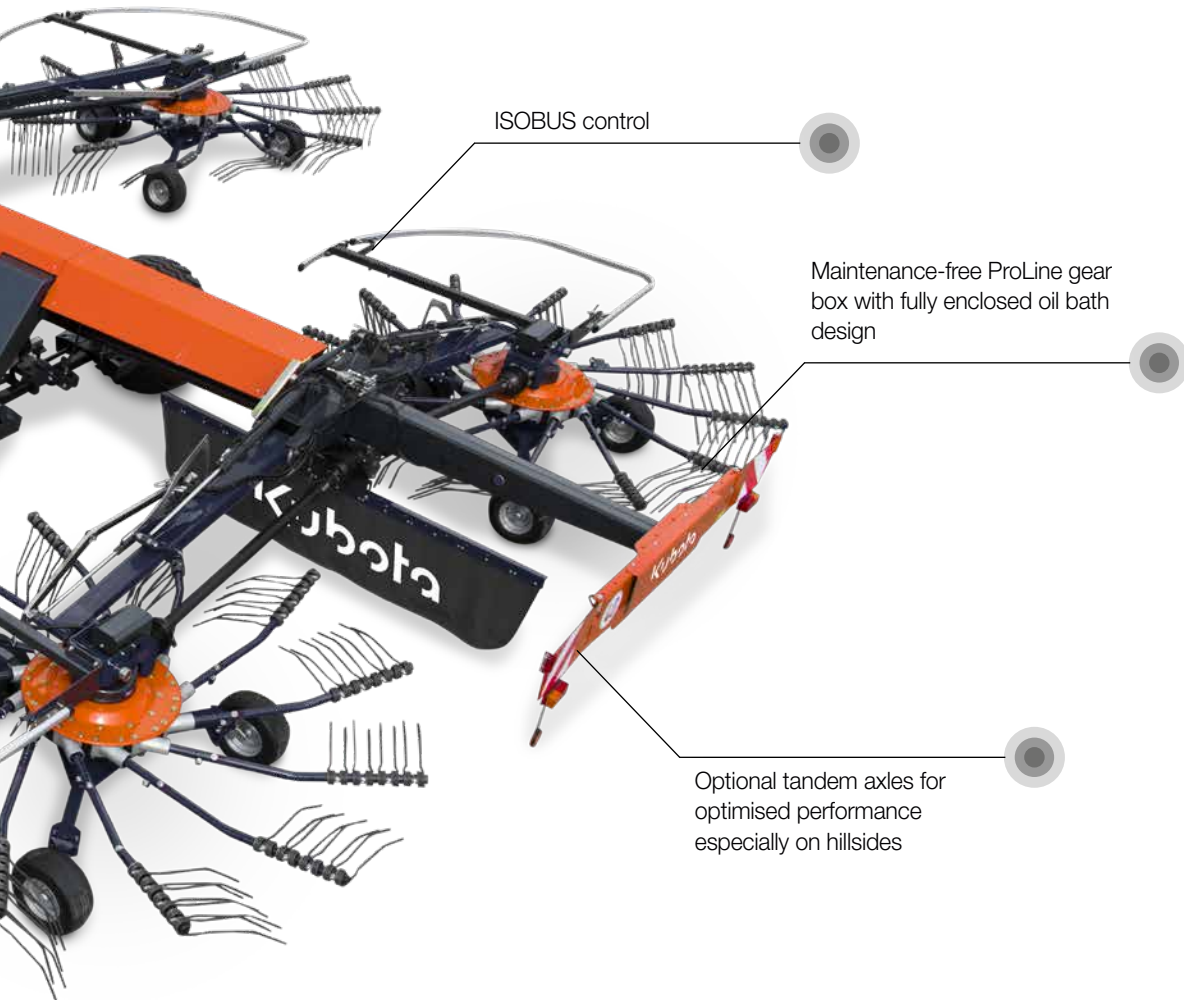

4. Tandem axle

Optional tandem axle available for front and rear rotors. The tandem axle has one fixed wheel for additional stability specially on hillside, the other one can steer to limit the scrubbing of the grass sward in curves to a minimum.



5. iM Farming ISOBUS

Advanced operation possibilities: Individual lifting, working width, height adjustment functions are controlled easily from each Isobus ready Terminal or Isomatch Tellus Go+ / Pro. If more comfort is needed also a joystick such as the Isomatch Grip can be added.



6. Electric height adjustment

RA4513 Pro is optionally available with electric height adjustment. Three heights can be preset and stored, allowing the user much faster changeover compared to 'master-slave' systems when changing from one to the other field condition, as setting can already be changed on the way.



What is shown on the screen?

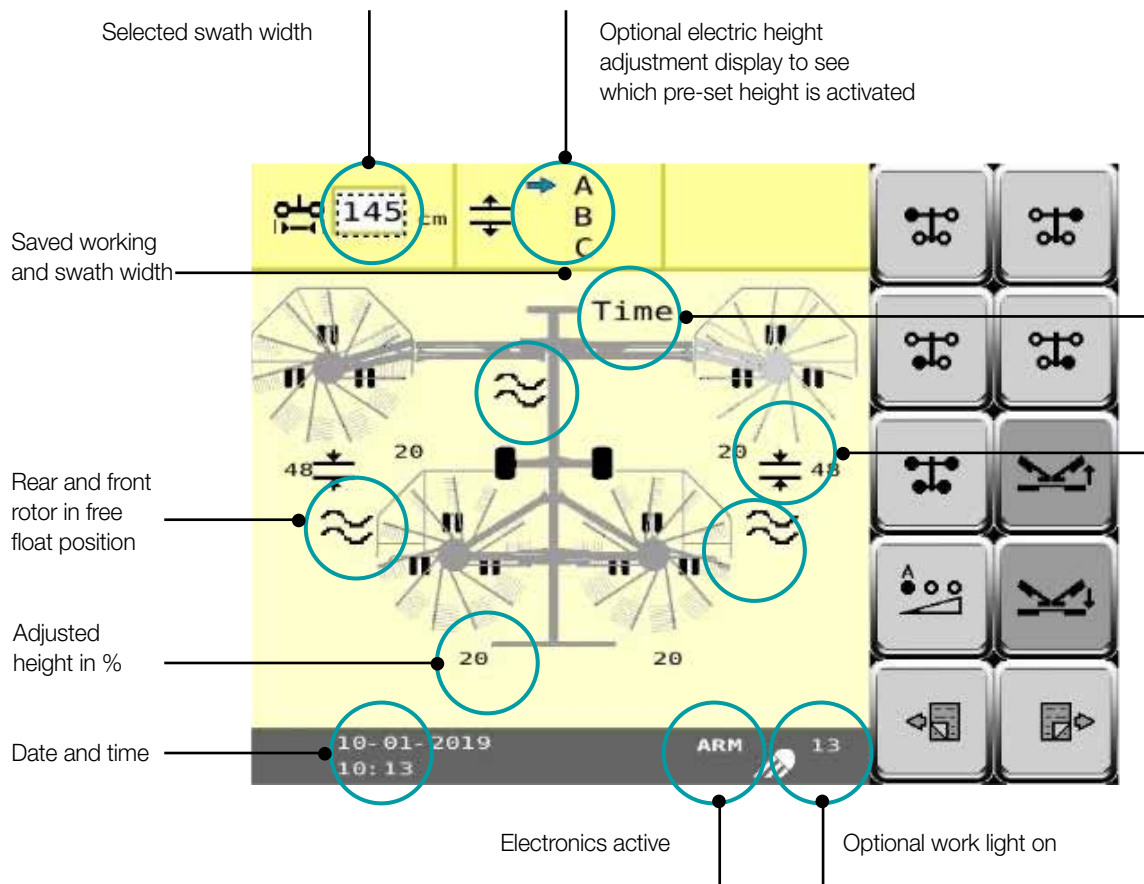

- Set up headland-Management:
- Time: use a time delay
 - Wheel: use wheel speed
 - Ground: use ground speed (Radar/ GPS)
 - Manual: Manual lifting of front and rear rotor with two times pressing of lifting or lowering button.

Working height change from 20 to 48%

Extended functionality – Easier to use

With only 5 pages it is possible to have more functionality per page and less shifting of pages
(Start screen)

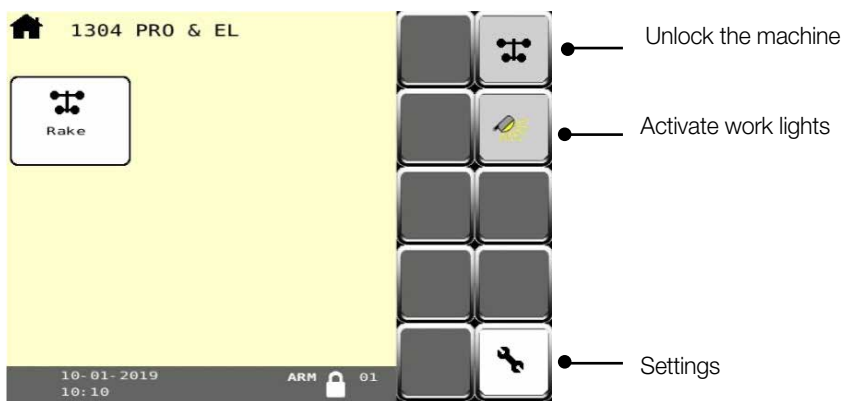

(Transport folding)

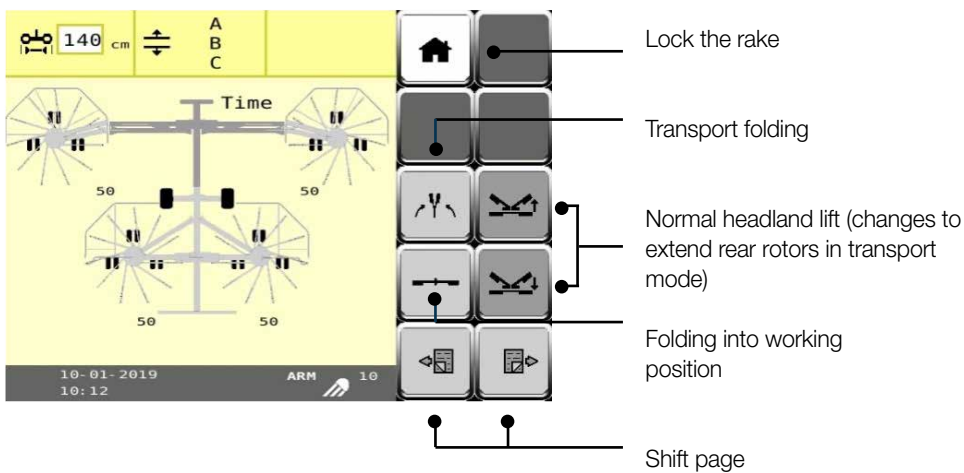



Extended functionality – Easier to use

(Operation page)

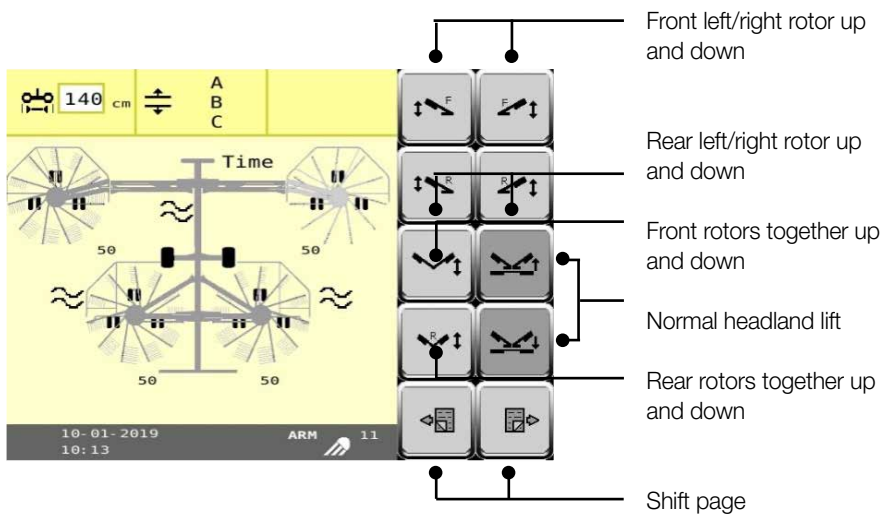

(Working and swath width)

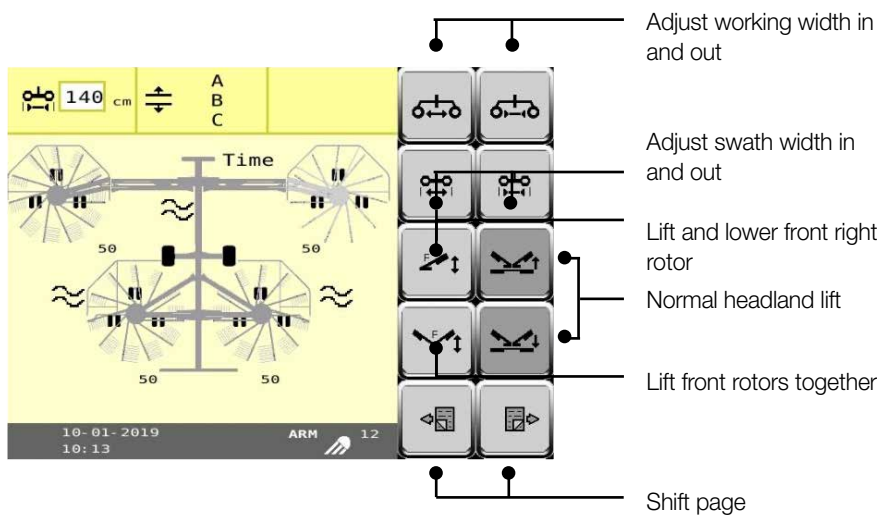

Extended functionality – Easier to use

(Height adjustment)

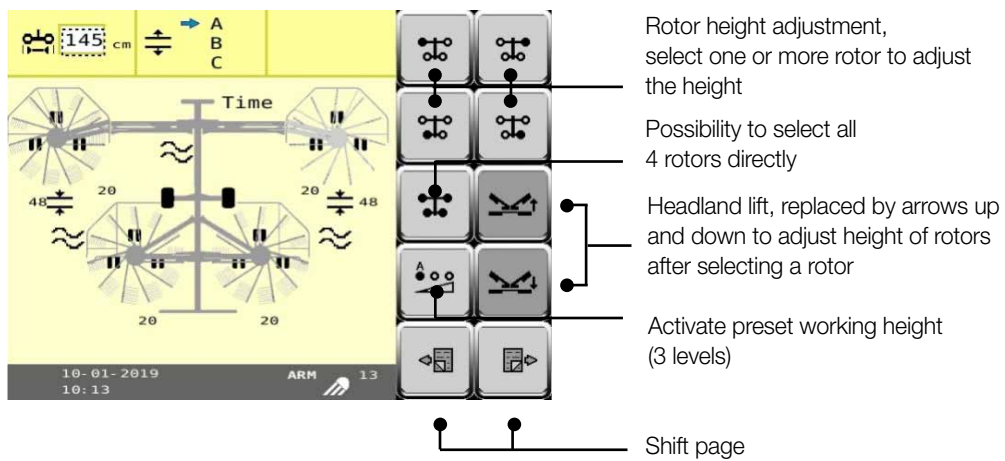



#RA4515

Kubota RA4515 benefits

Passive BreakBack protection on front rotors

Only rake in this size with steerable carrier axle to go through sharp corners and field entrances

Full ISOBUS controlled

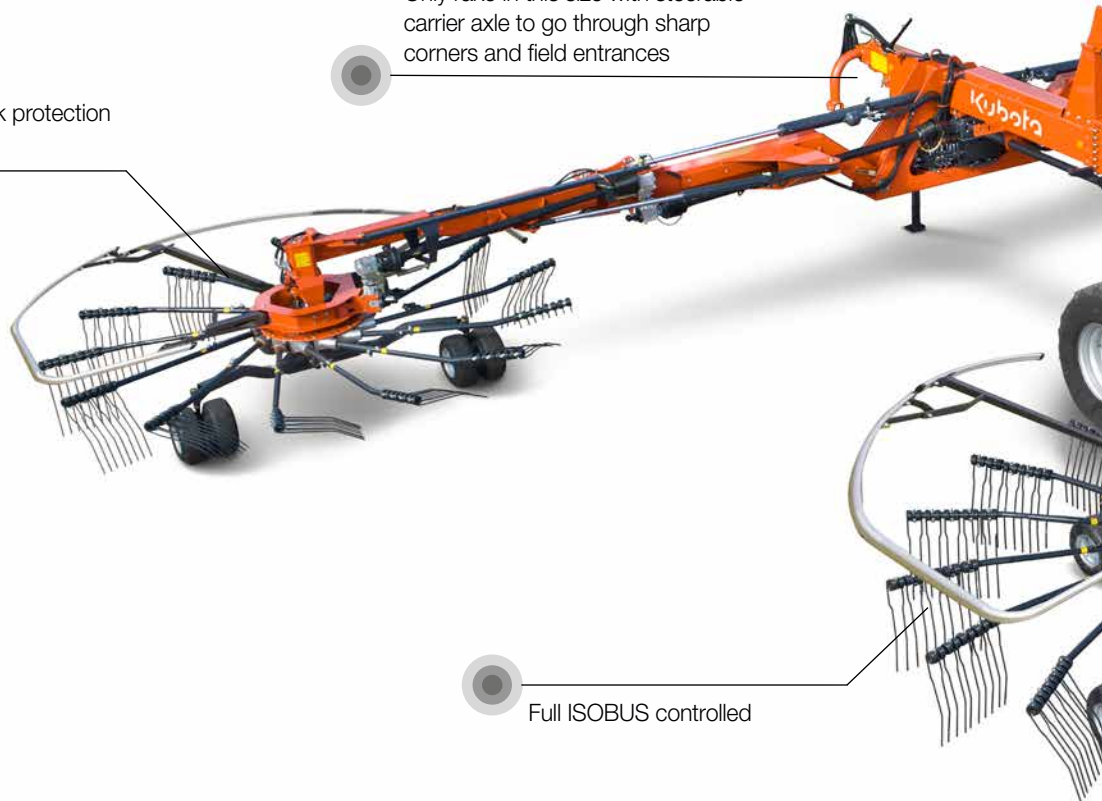

1. Break Back protection

The unique design of the front arms is protected with a break back system. In case the outer frame is stressed due to a collision it will be released rearwards to protect the frame structure. The system is integrated in the working width adjustment.

2. Hydraulic suspension

Adjustable hydraulic suspension on the front arms takes the weight of the support arm away from rotor. The hydraulics are operated on load sensing reducing fuel consumption, but also with possibility to run on constant flow.

3. Individual working width

The working width can be pre-set in the system. Some situations require adaptations. To not lose too much efficiency we can change working width for each side individually. With just one button the machine is returning back to the pre-set configuration.

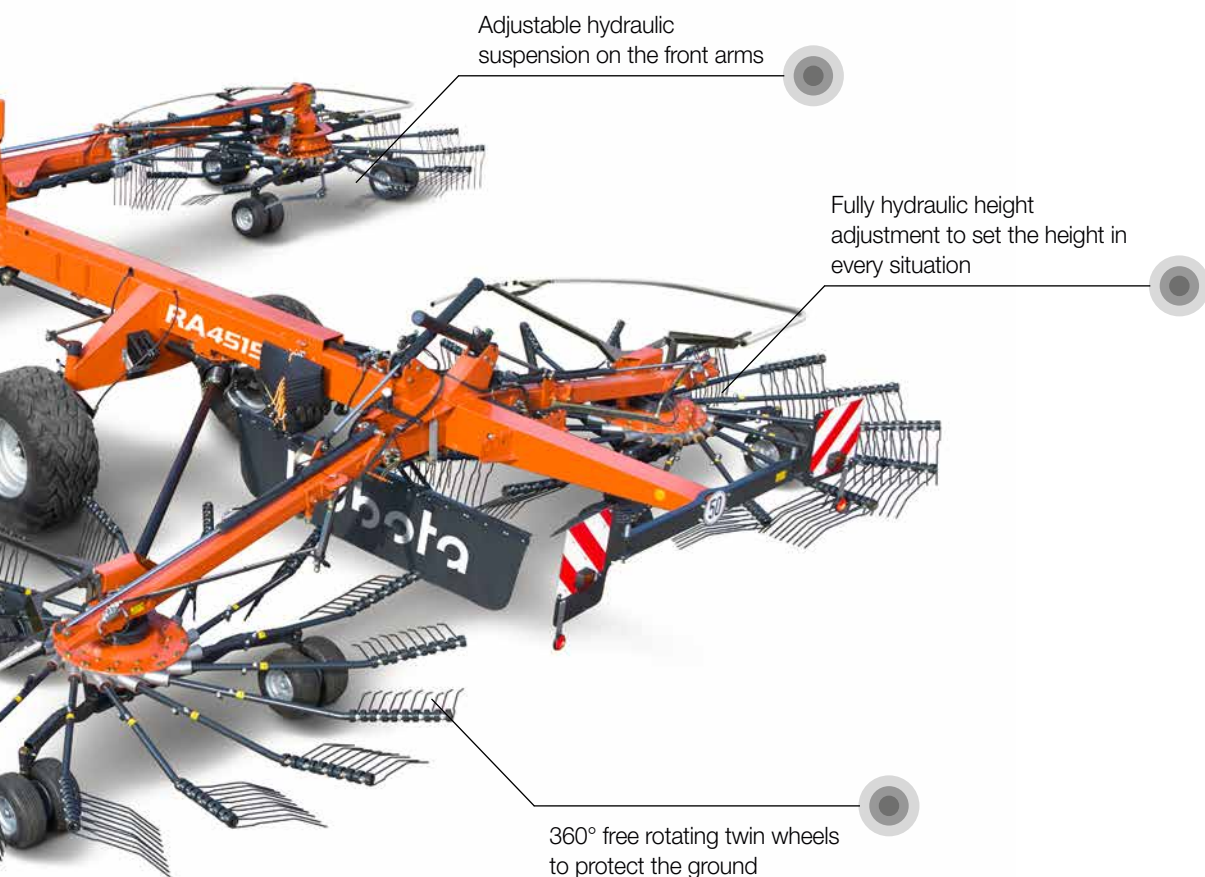

4. Free rotating twin wheels

The undercarrier of the rotors is equipped with three twin wheels rotating 360°. This allows narrow turns without scrubbing the grass sward. On top a fast adjustment of the working width is possible under all conditions. The twin wheels also precisely guide the rotor also in difficult conditions.

5. Steered transport wheels

With the unique and patented steered transport wheels it is much easier to access narrow field entrances. In addition, the steered wheels are outstanding in hilly conditions to compensate any downhill drift. Automised functions for headland lift and transport folding ensures the wheels are straight again.

6. iM Farming ISOBUS

Fully ISOBUS compatible, with no separate control terminal needed. It will plug directly into an ISOBUS compatible tractor. Easier connection between tractors and implements (Plug & Play).





What is shown on the screen?

Adjusted working and swath width

Saved working and swath width

Set up suspension

Red bar shows set suspension level. Green the real suspension

Rear and front rotor in free float position

Hydraulic activated

Joystick connected

Time

Set up headland-Management:

- Time: use a time delay
- Wheel: use wheel speed
- Ground: use ground speed (Radar/GPS)
- Manual: Manual lifting of front and rear rotor with two times pressing of lifting or lowering button.

Extended functionality – Easier to use

With only 6 pages it is possible to have more functionality per page and less shifting of pages
(Start screen)

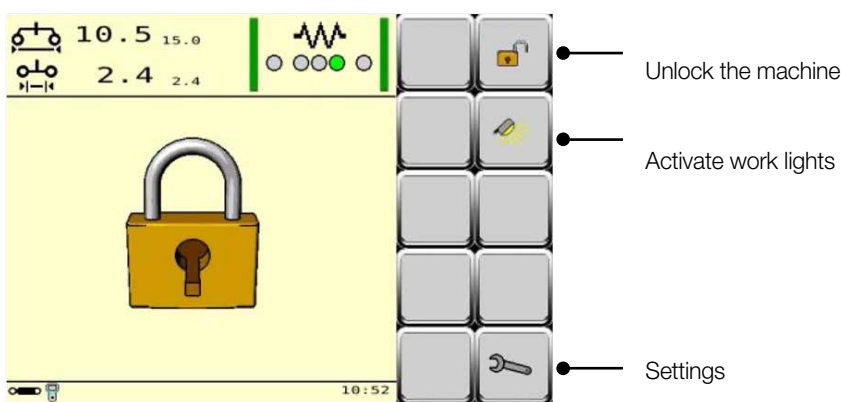

(Special operations)

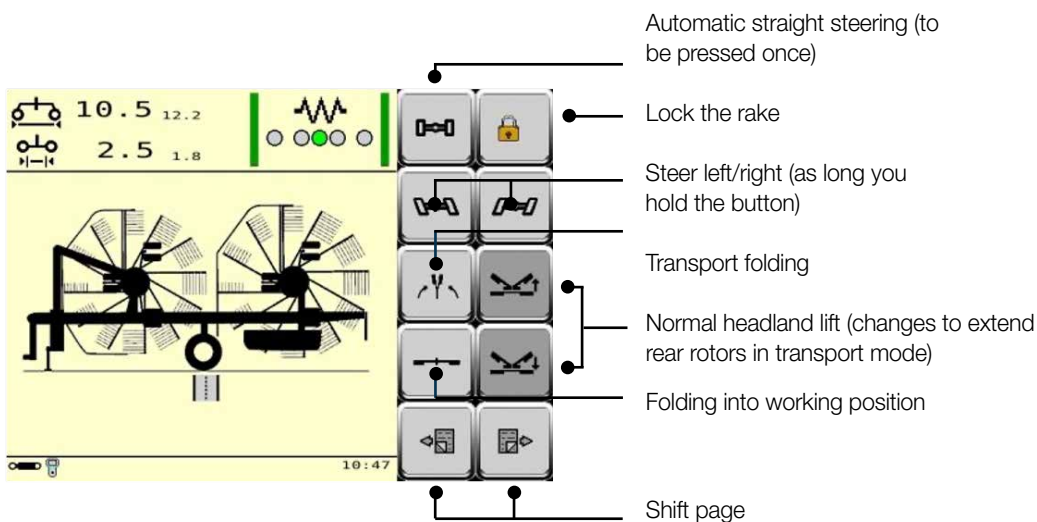



Extended functionality – Easier to use

(Operation page)

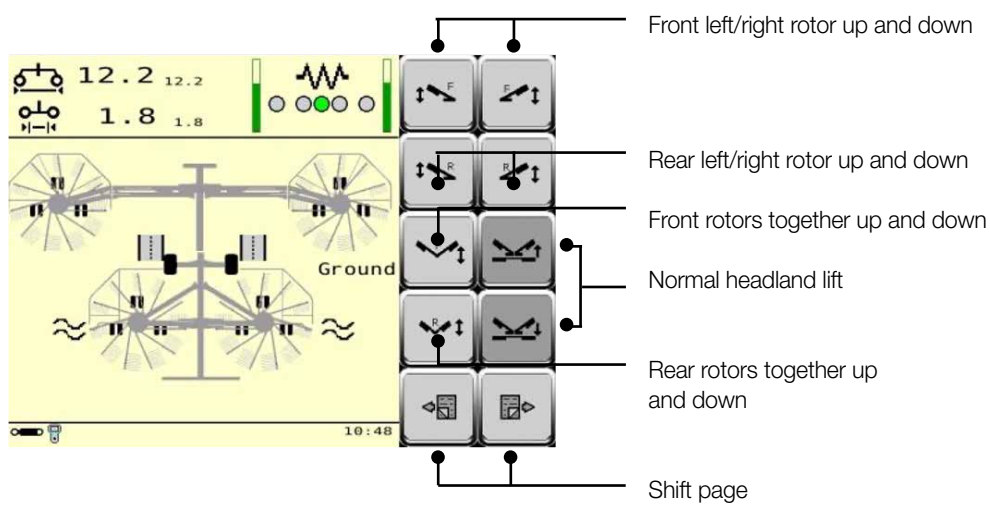

(Working and swath width)

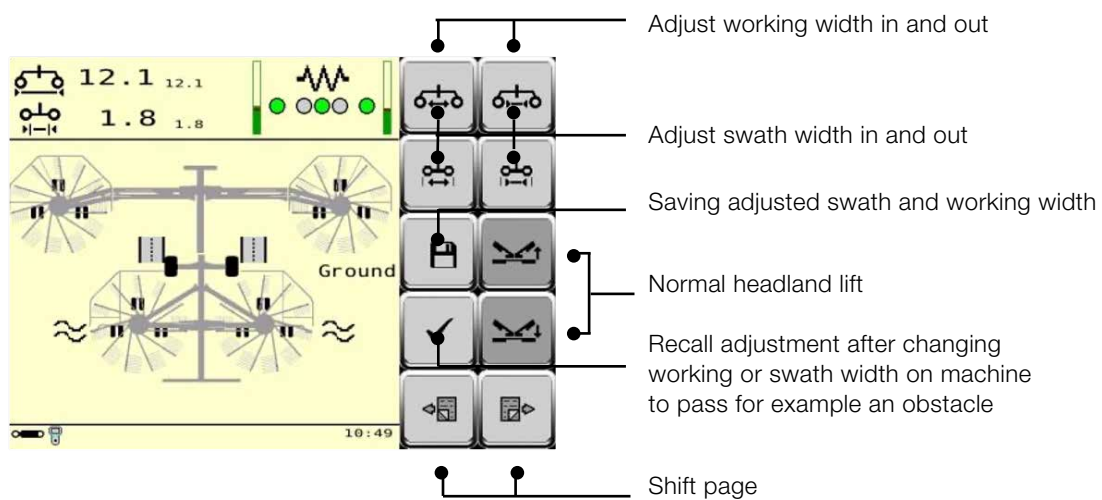

Extended functionality – Easier to use

(Raking the headland)

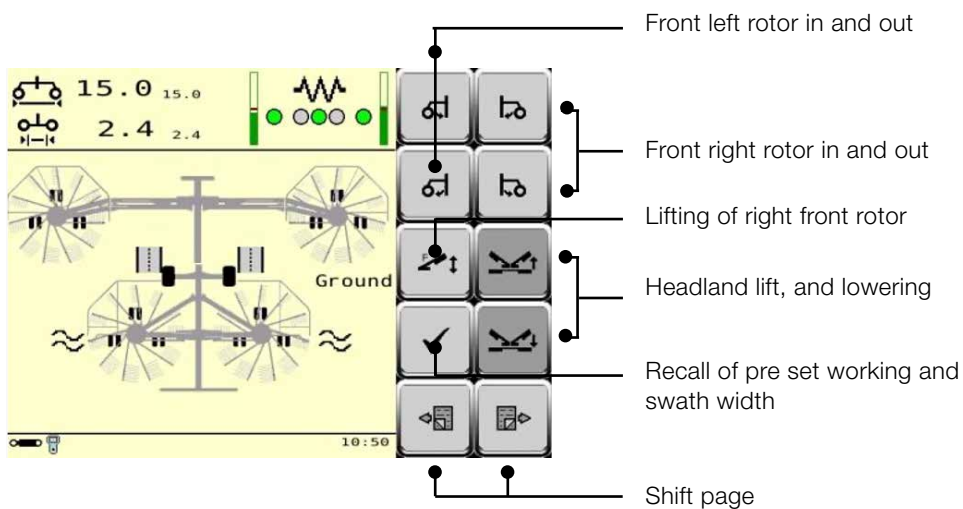

(Height adjustment)

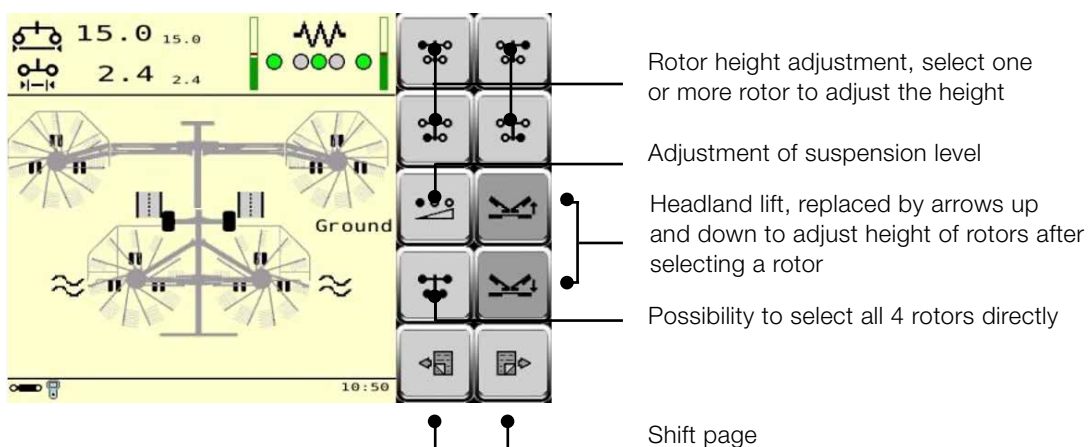



Kubota RA4012

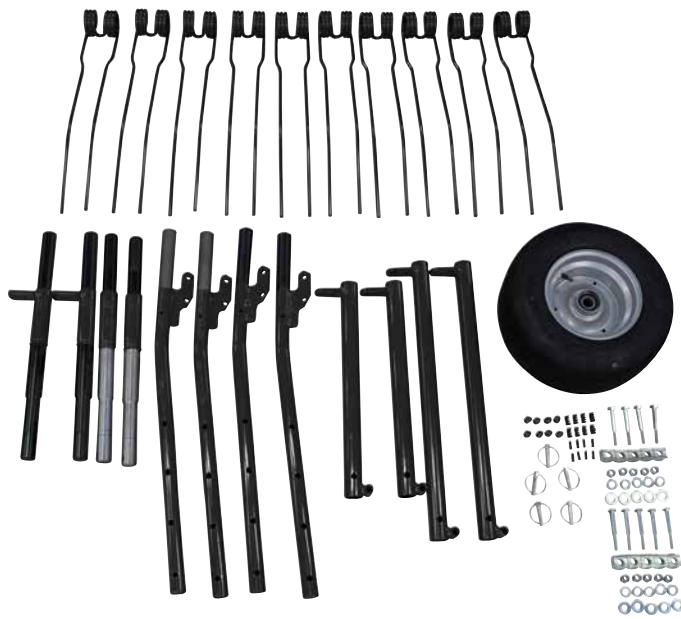

Starter kit



Spare wheel



Tandem axle for two rotors



Tine savers



Single side lift front rotors

Kubota RA4513



Starter kit



Spare wheel



Tandem axle for two rotors



Detachable tine arms



Tine savers



Single side lift front rotors



Kubota RA4513 Pro



Starter kit



Detachable tine arms



Spare wheel



3 work lights



Tine savers



Tandem axle for two rotors



IsoMatch Tellus GO+



IsoMatch Tellus Pro



IsoMatch Grip

Kubota RA4515

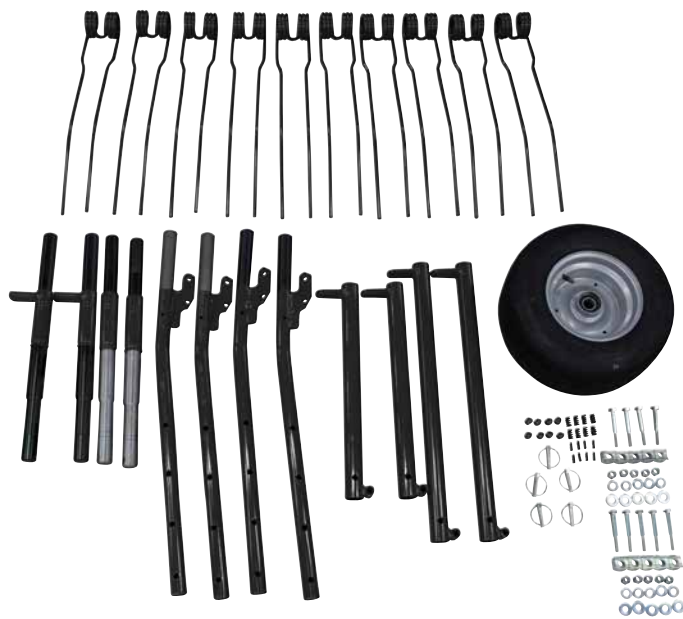

Starter kit



Detachable tine arms



Spare wheel



3 work lights



Hydraulic steering



Tine savers



IsoMatch Grip



IsoMatch Tellus Pro



IsoMatch Tellus GO+

The company reserves the right to change the above specifications without notice. This brochure is for descriptive purpose only. Some of the items pictured in this brochure are optional and not standard equipment. Please consult your local Kubota dealer for warranty, safety or product information. For your safety, Kubota strongly recommend the use of a seat belt in all applications.

©2021 Kverneland Group Kerteminde AS

