



PRODUCT CATALOGUE

Proven Landscape Technology

LANDSCAPE
FORESTRY
CULTIVATION
REMOTE

Bomford Turner

Proven Landscape Technology

They say there is no substitute for experience, we at Bomford agree. Pioneering innovative design in engineering since the late 1800's, Bomford have always been the leaders in their field.

Innovation And Durability

From developing labour saving road building machinery after the Napoleonic wars to the inception and development of the first Arm Mowers in the late 40's, right up to the present day state-of-the-art machinery, we live and breath innovation.

Our latest product catalogue showcases our full range of vegetation control products that are renowned for their strength in engineering and product durability.

On-Going Product Development

At Bomford, we are always looking to develop our product range and respond to the demands of our customers. Whether this means expanding the range of our impressive Flailbot machines, introducing a telescopic version of the popular Buzzard arm mower or offering a Flex option on our Dyna-Drive cultivator, you can sure we won't be standing still when it comes to finding the right solutions.



What's this?

These are QR codes. When you scan them with your smart phone or tablet you will be taken directly to the full product page on our website. Most phones have QR code reading built in using the camera. Alternatively you can download an app from your OS's app store.

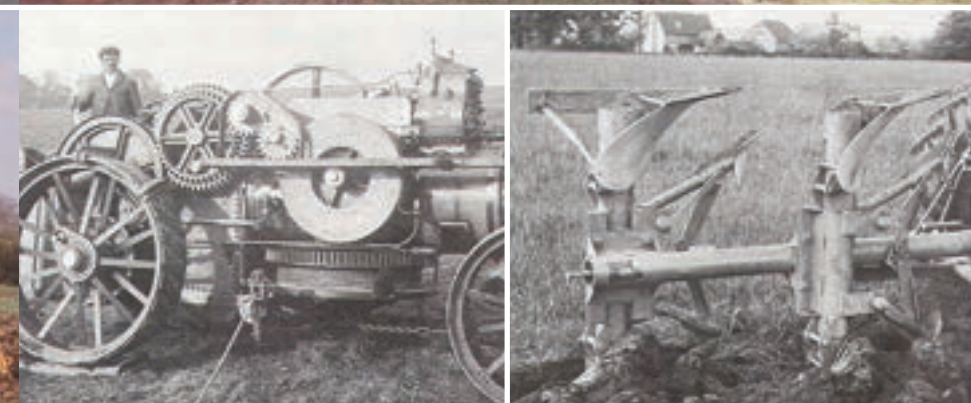
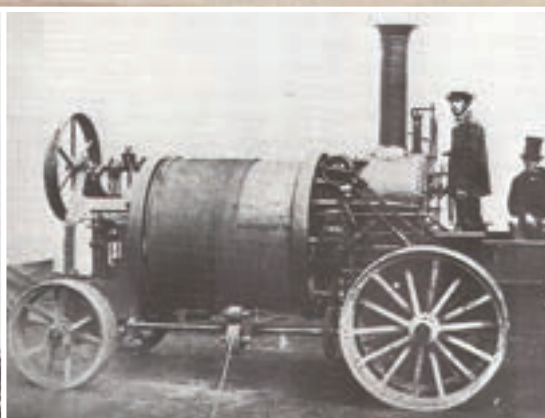

Contents

Landscape: Arm Mowers

Microklippa	6
Wren	8
Robin	10
Raven	12
Osprey	14
Kestrel Evo 'E'	16
Kestrel Evo 'S'	18
Kestrel Evo Power Plus	20
Kestrel Evo 'S' Forward	22
Kestrel Evo 'S' VFA	24
Kestrel Evo 'S' Front Mounted	26
Hawk Evo	28
Hawk Evo Power Plus	30
Hawk Evo Forward	32
Hawk Evo VFA	34
Falcon Evo	36
Falcon Evo Forward	38
Falcon Evo VFA	40
Falcon Evo Telescopic VFA	42
Front Mount Range	44
Buzzard Evo	46
Buzzard Evo Forward	48
Buzzard Evo Telescopic VFA	50
B71 & B80M	52
B81.81	54
Eagle	56

Landscape: Flail Mowers & Toppers

Turbo Mower	60
Turbo Mower Offset	62
Raptor	63
Twin-Blade	64
Twin-Blade HD	66
Tri-Blade	67
Tri-Wing	68
Forestry	
Buccaneer	72
Hurricane	74
Remote	
Flailbot Mini	78
Flailbot Compact T4F	80
Flailbot Original T4F	82
Flailbot Supreme T4F	84
Cultivation	
Dyna-Drive	88
Fittings & Controls	
Heads	92
Attachments	94
Flails	96
Tractor Fittings	98
Controls	100
Service & Support	102

LANDSCAPE

Arm Mowers

The Bomford Turner range of Arm Mowers provides a vast choice in both specification and budget.

Starting from the smallest compact tractor to large watercourse management models, there is a model for every landscape. Machines are built to the highest standards in our UK factory with the utmost care and attention given to ease of control and operator comfort.



Want to know more about our Arm Mowers range?

Scan the QR code with a smart phone or tablet to instantly view the page.



Arm Mower Range

Microklippa	6
Wren	8
Robin	10
Raven	12
Osprey	14
Kestrel Evo 'E'	16
Kestrel Evo 'S'	18
Kestrel Evo Power Plus	20
Kestrel Evo 'S' Forward	22
Kestrel Evo 'S' VFA	24
Kestrel Evo 'S' Front Mounted	26
Hawk Evo	28
Hawk Evo Power Plus	30
Hawk Evo Forward	32
Hawk Evo VFA	34
Falcon Evo	36
Falcon Evo Forward	38
Falcon Evo VFA	40
Falcon Evo Telescopic VFA	42
Front Mount Range	44
Buzzard Evo	46
Buzzard Evo Forward	48
Buzzard Evo Telescopic VFA	50
B71 & B80M	52
B81.81	54
Eagle	56

Microklippa

The Microklippa is very popular with estate managers and horticulturists who admire the Microklippa's fine cutting capabilities when hedge trimming and the versatility of the right or left hand cutting.

The Microklippa can be used on a range of power units from small compact tractors to small pivot steer loaders, in conjunction with a front mount kit.

Key Features

- 3.2m or 3.5m reach
- Left or right hand cutting (swing over capability)
- Cable or Electronic Proportional Controlled (EPC) options
- Front mount option and 16-22 litres per minute



Want to know more about the Microklippa range?

Scan the QR code with a smart phone or tablet to instantly view the page.



Cutter bar
Ideal for trimming ornamental and standard hedgerows up to 20mm thick.



Auto swingover latch
To operate fully extend second arm, allowing single operation from left to right.



Gravity breakout
To protect tractor and machine when cutting.

Product Specification

● Standard ○ Optional — Not Available

Microklippa	3.2m (10'5")	3.5m (11'5")
Tractor requirements		
Minimum horse power	15hp	15hp
Minimum weight	550kg / 1213lbs	550kg / 1213lbs
Base unit mounting options		
Front mount	—	—
Mid-mount	—	—
Rear mount	●	●
Three point linkage (Cat 11)	●	●
Axle bracket	—	—
Overall machine parameters		
Machine weight with head and oil	192kg / 423lbs	201kg / 443lbs
Capacity of oil tank	—	—
Controls		
Cable control (CC)	●	●
Electronic proportional control (EPP)	○	○
Intelligent control system (ICS)	—	—
Low pressure hydraulics (LPH)	—	—
Cable rotor reverse	—	—
Electronic rotor reverse	—	—

Microklippa	3.2m (10'5")	3.5m (11'5")
Arm features and main frame		
Telescopic arm	—	—
Telescopic arm stroke	—	—
Power slew	—	—
Power slew angle	—	—
Gravity breakout	●	●
Hydraulic breakout	—	—
Armfloat - manual	—	—
Armfloat - electronic	—	—
Headfloat - manual	—	—
Headfloat - electronic	—	—
Left hand cutting	—	—
Right hand cutting	—	—
Left and right hand cutting	●	●
Cutting heads		
Rotary Heads	—	—
1.2m and 1.5m cutterbars	○	○
Ditch Cleaner	—	—



Small but flexible
Impressive reach characteristics for a compact machine.

Working Reach

Head used for calcs: 1.2m Cutterbar

	Microklippa 3.2m (10'5")	Microklippa 3.5m (11'5")
A	3.10m / 10'2"	3.4m / 11'2"
B	3.20m / 10'6"	3.50m / 11'6"
C	2.00m / 6'6"	2.30m / 7'7"
D	3.10m / 10'2"	3.50m / 11'6"
E	4.20m / 13'9"	4.50m / 14'9"
X	1.0m / 3'4"	1.00m / 3'4"
Y	1.34m / 4'7"	1.34m / 4'7"

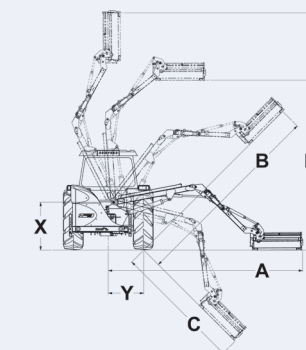

Wren

Compact yet powerful, the Wren is the latest addition to the range of arm mowers from Bomford Turner and offers an excellent entry-level solution to your landscaping maintenance needs.

Fitted with twin pumps and fully independent hydraulics, the Wren can operate a range of different attachments.

Key Features

- 3.5m reach
- Left or right hand cutting option
- Cable control
- Mechanical breakout
- Cutter bar option



Want to know more about the Wren range?

Scan the QR code to the left with a smart phone or tablet and compatible app to instantly view the page.

Alternatively visit: www.bomford-turner.com/landscape/arm-mowers/wren/



Cable rotor reverse
Fitted as standard. Ideal for cutting both brush and grass.



Fully independent hydraulics
For continuous use. Twin pumps with separate oil tank.



Multi-purpose flails
For grass and hedges.

Product Specification

● Standard ○ Optional — Not Available

Wren	3.5m (11'5")
Tractor requirements	
Minimum horse power	25hp
Minimum weight	750kg / 1653lbs
Base unit mounting options	
Front mount	—
Mid-mount	—
Rear mount	●
Three point linkage (Cat 1 & Cat 11)	●
Axle bracket	—
Overall machine parameters	
Machine weight with head and oil	350kg / 772lbs
Capacity of oil tank	55L / 14.5USG
Controls	
Cable Control (CC)	●
Electronic proportional control (EPP)	—
Intelligent control system (ICS)	—
Low pressure hydraulics (LPH)	—
Cable rotor reverse	●
Electronic rotor reverse	—
Hydraulic System	
System capability	30hp
Pump flow rate (min)	50L / 13.2USG
Pump type (Gear / Piston / Helical)	Gear
Pump arrangement (Twin / Tandem Inline)	Twin
Independent hydraulics	●
Oil cooler	○

Wren	3.5m (11'5")
Arm features and main frame	
Telescopic arm	—
Telescopic arm stroke	—
Power slew	—
Power slew angle	—
Gravity breakout	●
Hydraulic breakout	—
Armfloat - manual	●
Armfloat - electronic	—
Headfloat - manual	●
Headfloat - electronic	—
Left hand cutting	●
Right hand cutting	●
Left and right hand cutting	—
Cutting heads	
0.8m Flailhead	●
1.5m Cutter Bar	○



Gravity breakout system
For protecting drive and machine during operation.

Working Reach

Head used for calcs: 0.8m Flail Head

	Wren 3.5m (11'5")
A	3.3m / 10'10"
B	3.3m / 10'10"
C	2.2m / 7'3"
D	1.8m / 5'11"
E	3.5m / 11'6"
X	1.0m / 3'3"
Y	0.7m / 2'4"

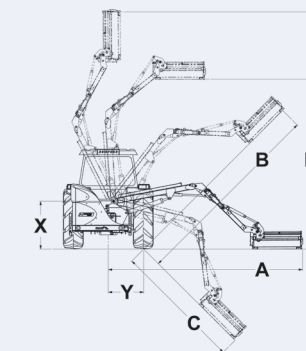

Robin

The Robin is a professional compact Arm mower - perfect for amenity and estate use and also a firm favourite with small farmers as it can verge mow or hedge trim just as well as some of our larger models.

The Robin has many variants, and is available as front mount, along with small wheel loader and skid steer options.

Key Features

- 3.4m or 4.3m reach
- Parallel linkage as standard
- Hydraulic breakout on second arm standard
- End drive cutting head or cutter bar
- Electronic Proportional Controlled (EPC) optional
- Front mount option
- Low friction cable control



Want to know more about the Robin range?

Scan the QR code with a smart phone or tablet to instantly view the page.



Hydraulic breakout

Fitted as standard this protects both machine and driver.



Fully independent hydraulics

For continuous use. Twin pumps with separate oil tank.



Front mounted option

Fitting kits available for various prime movers. Contact for details.

Product Specification

● Standard ○ Optional — Not Available

Robin	3.4m (11'2")	4.3m (14'2")
Tractor requirements		
Minimum horse power	30-40hp	30-40hp
Minimum weight	1300kg / 2866lbs	1500kg / 3307lbs
Base unit mounting options		
Front mount	○	○
Mid-mount	—	—
Rear mount	●	●
Three point linkage (Cat 11)	●	●
Axle bracket	—	—
Overall machine parameters		
Machine weight with head and oil	594kg / 1310lbs	670kg / 1477lbs
Capacity of oil tank	80L / 21.1USG	80L / 21.1USG
Weight of machine with oil but without head	464kg / 1023lbs	530kg / 1168lbs
Controls		
Cable control (CC)	●	●
Electronic proportional control (EPP)	○	○
Intelligent control system (ICS)	—	—
Low pressure hydraulics (LPH)	—	—
Cable rotor reverse	○	○
Electronic rotor reverse	○	○
Hydraulic System		
System capability	30hp	30hp
Pump flow rate	50L / 13.2USG	50L / 13.2USG
Pump type (Gear / Piston / Helical)	Gear	Gear
Pump arrangement (Twin / Tandem / Inline)	Twin	Twin
Independent hydraulics	●	●
Oil cooler	—	—
Accessories		
Road lights	—	—
Debris blower	—	—
Cab guard kit	○	○

Robin	3.4m (11'2")	4.3m (14'2")
Arm features and main frame		
Telescopic arm	—	—
Telescopic arm stroke	—	—
Power slew	—	—
Power slew angle	—	—
Gravity breakout	—	—
Hydraulic breakout	●	●
Armfloat - manual	●	●
Armfloat - electronic	○	○
Headfloat - manual	○	○
Headfloat - electronic	○	○
Left hand cutting	○	○
Right hand cutting	○	○
Arm attachments available		
Variable track bracket (VTB)	—	—
Sheartrim cutter bar	○	○
Pro-Saw	○	○
Ditch cleaner	—	—
Rotary head	—	—
Cutting heads (For Flail compatibility see page 97)		
905mm flail head with 102mm roller	○	○
1000mm flail head with 102mm roller	○	○
1.2m and 1.5m cutterbars	○	○

Note: A Frame required for Kubota model tractors.

Working Reach

Head used for calcs: 905mm

	Robin 3.4m (11'2")	Robin 4.3m (14'2")
A	3.4m / 11'2"	4.3m / 14'2"
B	3.0m / 9'10"	4.0m / 13'2"
C	1.98m / 6'6"	2.98m / 9'10"
D	3.3m / 10'10"	4.3m / 14'2"
E	4.3m / 14'11"	5.3m / 17'5"
X	1.0m / 3'4"	1.0m / 3'4"
Y	1.34m / 4'7"	1.34m / 4'7"

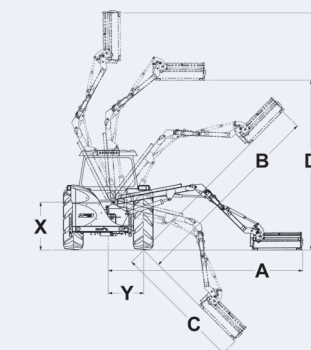

Reach options

There are 2 reach options available with this machine - 3.4m and 4.3m.



Raven

The Raven is a rear mounted Arm mower designed to meet the demands of smaller agricultural, horticultural, landscape & amenity customers. The rugged design ensures excellent performance for a small, compact machine and is suitable for any tractor over 40HP.

With a choice of 4.0m or 4.7m reach, and the familiar cable lever control the Raven can also be fitted with the popular LPH "Low Pressure Hydraulic" or EPP "Electronic Proportional Control" Joysticks, which gives proportional control of the arm and switch control of the head angle. Arm float functions are available via buttons on the rear of the stick allowing ultimate control when operating the machinery, whether hedge cutting or verge mowing.

Key Features

- Choice of 4.0m or 4.7m reach
- Direct drive cutting head or cutter bar
- Cable Control with options for LPH & EPP
- Chain stabiliser kit
- Tubular 3 point linkage option
- Choice of flails



Want to know more about the Raven range?

Scan the QR code with a smart phone or tablet to instantly view the page.



Rugged design
With oversized arms this machine is perfect for cutting grass.



Integral tank mainframe
Reduced weight makes the Raven compatible with smaller tractors.



Independent hydraulics
For continuous use. Twin pumps with separate oil tank.

Product Specification

● Standard ○ Optional — Not Available

Raven	4.0m (13'2")	4.7m (15'8")
Tractor requirements		
Minimum horse power	45hp	45hp
Minimum weight	1800kg / 3968lbs	2000kg / 4409lbs
Base unit mounting options		
Front mount	—	—
Mid-mount	—	—
Rear mount	●	●
Three point linkage (Cat 11)	●	●
Axle bracket	—	—
Overall machine parameters		
Machine weight with head and oil	640kg / 1411lbs	680kg / 1499lbs
Capacity of oil tank	130L / 34.3USG	130L / 34.3USG
Weight of machine with oil but without head	480kg / 1058lbs	530kg / 1168lbs
Controls		
Cable Control (CC)	●	●
Low pressure hydraulics (LPH)	○	○
Electronic proportional control (EPP)	○	○
Intelligent control system (ICS)	—	—
Cable rotor reverse	●	●
Electronic rotor reverse	○	○
Hydraulic System		
System capability	45hp	45hp
Pump flow rate	74L / 19.5USG	74L / 19.5USG
Pump type (Gear / Piston / Helical)	Gear	Gear
Pump arrangement (Twin / Tandem Inline)	Twin	Twin
Independent hydraulics	●	●
Oil cooler	○	○
Accessories		
Road lights	—	—
Debris blower	—	—
Cab guard kit	●	●

Raven	4.0m (13'2")	4.7m (15'8")
Arm features and main frame		
Fixed forward arm	—	—
Folding forward arm	—	—
Variable folding arm	—	—
Telescopic arm	—	—
Telescopic arm stroke	—	—
Power slew	—	—
Power slew angle	—	—
Gravity breakout protection	●	●
Hydraulic breakout protection	—	—
Armfloat - manual operation	○	○
Armfloat - electronic operation	○	○
Head angle float	●	●
Left hand cutting	○	○
Right hand cutting	○	○
Left and right hand cutting	—	—
Arm attachments available		
Variable track bracket (VTB)	—	—
Sheartrim cutter bar	○	○
Pro-Saw	○	○
Ditch cleaner	—	—
Rotary head	—	—
Cutting heads (For Flail compatibility see page 97)		
950mm head with 102mm roller	●	●
1007mm head with 102mm roller	○	○
1107mm head with 115mm roller	○	○
1.5m sheartrim cutterbar	○	○



Gravity breakout
For machine and operator safety.

Working Reach

Head used for calcs: 950mm

	Raven 4.0m (13'2")	Raven 4.7m (15'8")
A	4.0m / 13'2"	4.7m / 15'8"
B	3.52m / 11'7"	4.24m / 14'
C	2.51m / 8'3"	3.17m / 10'5"
D	2.77m / 9'1"	3.38m / 11'1"
E	4.12m / 13'6"	4.81m / 15'9"
X	1.0m / 3.4m	1.0m / 3.4m
Y	1.34m / 4'7"	1.34m / 4'7"

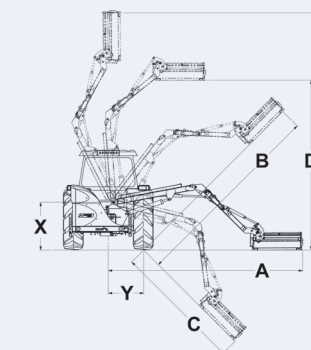

Osprey

The Osprey is the perfect choice for the small scale and co-operative agricultural markets. This economic entry level machine would also be of interest to sports and amenity managers.

With a choice of 4.5m or 5.0m reach, with an impressive 110 degrees of power slew and hydraulic breakout as standard, the Osprey is ideal where access is a challenge to the operator. The mainframe of the machine is close coupled to the tractor and this allows the machine to be fitted to smaller tractors than most other competitor models on the market.

Arm attachments can include a choice of flail heads for control of grass, hedges and light brush along with the Sheartrim cutter bar or Pro-Saw attachments for control of heavier brush.

Key Features

- 4.5 or 5.0m reach
- Choice of heads
- Low friction cable, LPH or EPP controls
- Three point linkage mounted
- 110° power slew
- Hydraulic breakout protection



Want to know more about the Osprey range?

Scan the QR code with a smart phone or tablet to instantly view the page.



Hydraulic slew & breakout
110° of slew and hydraulic breakout makes the Osprey very adaptable.



Secure adjustable parking stands
For uncoupling the machine on a variety of surfaces safely.



Adjustable cowl linkage
Giving a larger range of head movement.

Product Specification

● Standard ○ Optional — Not Available

Osprey	4.5m (14'9")	5.0m (16'5")
Tractor requirements		
Minimum horse power	70hp	75hp
Minimum weight	2300kg / 5070lbs	2500kg / 5512lbs
Base unit mounting options		
Front mount	—	—
Mid-mount	—	—
Rear mount	●	●
Three point linkage (Cat 11)	●	●
Axle bracket	—	—
Overall machine parameters		
Machine weight with head and oil	820kg / 1808lbs	860kg / 1896lbs
Capacity of oil tank	130L / 34.3USG	130L / 34.3USG
Weight of machine with oil but without head	700kg / 1543lbs	740kg / 1632lbs
Controls		
Cable Control (CC)	●	●
Low pressure hydraulics (LPH)	○	○
Electronic proportional control (EPP)	○	○
Intelligent control system (ICS)	—	—
Cable rotor reverse	●	●
Electronic rotor reverse	○	○
Hydraulic System		
System capability	45hp	45hp
Pump flow rate	74L / 19.5USG	74L / 19.5USG
Pump type (Gear / Piston / Helical)	Gear	Gear
Pump arrangement (Twin / Tandem Inline)	Twin	Twin
Independent hydraulics	●	●
Oil cooler	○	○
Accessories		
Road lights	—	—
Debris blower	—	—
Cab guard kit	●	●

Osprey	4.5m (14'9")	5.0m (16'5")
Arm features and main frame		
Fixed forward arm	—	—
Folding forward arm	—	—
Variable folding arm	—	—
Telescopic arm	—	—
Telescopic arm stroke	—	—
Power slew	●	●
Power slew angle	110°	110°
Gravity breakout protection	—	—
Hydraulic breakout protection	●	●
Armfloat - manual operation	○	○
Armfloat - electronic operation	○	○
Head angle float	●	●
Left hand cutting	○	○
Right hand cutting	○	○
Left and right hand cutting	—	—
Arm attachments available		
Variable track bracket (VTB)	—	—
Sheartrim cutter bar	○	○
Pro-Saw	○	○
Ditch cleaner	—	—
Rotary head	—	—
Cutting heads (For Flail compatibility see page 97)		
950mm head with 102mm roller	●	●
1000mm head with 102mm roller	○	○
1257mm head with 102mm roller	○	○
1257mm head with 150mm roller	○	○
1107mm head with 115mm roller	○	○
1.5m sheartrim cutterbar	○	○



Compact transport

As a result of the 110° power slew the Osprey has a compact inline transport position.

Working Reach

Head used for calcs: 950mm

	Osprey 4.5m (14'9")	Osprey 5.0m (16'5")
A	4.55m / 14'11"	5.0m / 16'5"
B	4.33m / 14'2"	4.8m / 15'9"
C	2.3m / 7'6"	2.8m / 9'6"
D	3.7m / 12'1"	4.2m / 13'9"
E	4.7m / 15'5"	5.2m / 17"
X	1.0m / 3'4"	1.0m / 3'4"
Y	1.34m / 4'7"	1.34m / 4'7"

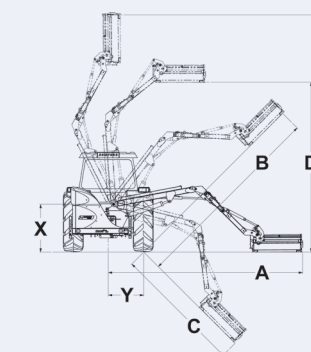

Kestrel Evo 'E'

The Kestrel Evo 'E' hedge trimmer and verge mower, with a 5m reach and a choice of flail heads or a 1.5m sheartrim cutterbar, is perfect for the farmer who needs professional features and robust design, offering real value for money.

A well designed, and cost effective machine, with mechanical breakout and cable controls as standard, the Kestrel Evo 'E' is the perfect model for small scale farmers and infrequent users. Very popular with dairy farmers who wish to maintain stock boundary hedges and water courses with hassle free operation and economic cost.

A choice of flail heads for control of grass, hedges and light brush. Upgrade options to the Pro-Trim series of cutting head and heavy duty Truecut flail are available.

Key Features

- 5m reach options
- Choice of flail heads or 1.5m cutter bar
- Twin pump independent hydraulics
- Cat 11 three point linkage mounted
- Non parallel or parallel linkage options
- Mechanical breakout protection



Want to know more about the Kestrel Evo E range?

Scan the QR code with a smart phone or tablet to instantly view the page.



Product Specification

● Standard ○ Optional — Not Available

Kestrel Evo 'E'	5.0m (16'5")	5.0m P (16'5")
Tractor requirements		
Minimum horse power	50hp	50hp
Minimum weight	3000kg / 6614lbs	3000kg / 6614lbs
Base unit mounting options		
Front mount	—	—
Mid-mount	—	—
Rear mount	●	●
Three point linkage (Cat 11)	●	●
Axle bracket	—	—
Overall machine parameters		
Machine weight with head and oil	920kg / 2028lbs	1000kg / 2505lbs
Capacity of oil tank	160L / 42.3USG	160L / 42.3USG
Weight of machine with oil but without head	720kg / 1587lbs	800kg / 1764lbs
Controls		
Cable Control (CC)	●	●
Low pressure hydraulics (LPH)	○	○
Electronic proportional control (EPP)	○	○
Intelligent control system (ICS)	—	—
Cable rotor reverse	○	○
Electronic rotor reverse	○	○
Hydraulic System		
System capability	45hp	45hp
Pump flow rate	74L / 19.5USG	74L / 19.5USG
Pump type (Gear / Piston / Helical)	Gear	Gear
Pump arrangement (Twin / Tandem Inline)	Twin	Twin
Independent hydraulics	●	●
Oil cooler	○	○
Accessories		
Road lights	○	○
Debris blower	○	○
Cab guard kit	●	●

Mechanical breakout
For machine and operator safety.

Optional oil cooler
Can be fitted in rear panel.

240° cowl bracket linkage
For a greater angle range.

Kestrel Evo 'E'	5.0m (16'5")	5.0m P (16'5")
Arm features and main frame		
Fixed forward arm	—	—
Folding forward arm	—	—
Variable folding arm	—	—
Telescopic arm	—	—
Telescopic arm stroke	—	—
Power slew	—	—
Power slew angle	—	—
Gravity breakout protection	●	●
Hydraulic breakout protection	—	—
Armfloat - manual operation	○	○
Armfloat - electronic operation	○	○
Head angle float	●	●
Left hand cutting	○	○
Right hand cutting	○	○
Left and right hand cutting	—	—
Arm attachments available		
Variable track bracket (VTB)	—	—
Sheartrim cutter bar	○	○
Pro-Saw	○	○
Ditch cleaner	—	—
Rotary head	—	—
Cutting heads (For Flail compatibility see page 97)		
1257mm head with 102mm roller	●	●
1257mm head with 150mm roller	○	○
1.2m Pro-Trim head with 115mm roller	○	○
1.2m Pro-Trim head with 150mm roller	○	○
1.5m Sheartrim cutterbar	○	○

Parallel arm options
Available for ease of operation when hedge cutting.

Working Reach

Head used for calcs: 1.2 Pro-Trim

	Kestrel Evo 'E' 5.0m (16'5")	Kestrel Evo 'E' 5.0m P (16'5")
A	5.06m / 16'7"	4.96m / 16'3"
B	4.97m / 16'4"	5.13m / 16'10"
C	3.63m / 11'11"	3.31m / 10'10"
D	4.05m / 13'3"	4.32m / 14'2"
E	5.98m / 19'7"	5.99m / 19'8"
X	1.00m / 3'4"	1.00m / 3'4"
Y	1.34m / 4'7"	1.34m / 4'7"

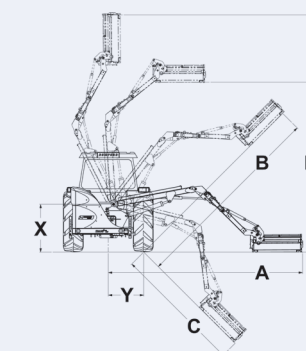

Kestrel Evo 'S'

The Kestrel Evo 'S' has been designed to provide significant reach for farmers who need to keep weight in mind whilst retaining the versatile features of a more expensive machine.

These features include integral road lighting, tubular 3 point linkage and power slew with hydraulic breakout.

Key Features

- 5m or 5.7m reach
- Parallel arm option
- Front mount option
- Choice of flails, heads and cutter bars
- Power slew
- Forward arm option



Want to know more about the Kestrel Evo S range?

Scan the QR code with a smart phone or tablet to instantly view the page.



Power slew and hydraulic breakout
For driver and machine safety.



Pro-Trim top drive motor head
Fitted as standard.



Road lights
Fitted as standard.

Product Specification

● Standard ○ Optional — Not Available

Kestrel Evo 'S'	5.0m (16'5")	5.0m P (16'5")	5.7m (18'8")	5.7m P (18'8")
Tractor requirements				
Minimum horse power	50hp	50hp	60hp	60hp
Minimum weight	3000kg 6614lbs	3000kg 6614lbs	3500kg 7716lbs	3500kg 7716lbs
Base unit mounting options				
Front mount	○	○	○	○
Mid-mount	—	—	—	—
Rear mount	●	●	●	●
Three point linkage (Cat 11)	●	●	●	●
Axle bracket	—	—	—	—
Sub Frame	—	—	—	—
Yoke	—	—	—	—
Overall machine parameters				
Machine weight with head and oil	1180kg 2601lbs	1180kg 2601lbs	1210kg 2268lbs	1210kg 2268lbs
Capacity of oil tank	160L 42.3usg	160L 42.3usg	160L 42.3usg	160L 42.3usg
Weight of machine with oil but without head	940kg 2072lbs	940kg 2072lbs	970kg 2139lbs	970kg 2139lbs
Controls				
Cable Control (CC)	●	●	●	●
Low pressure hydraulics (LPH)	○	○	○	○
Electronic proportional control (EPP)	○	○	○	○
Intelligent control system (ICS)	—	—	—	—
Cable rotor reverse	○	○	○	○
Electronic rotor reverse	—	—	—	—
Hydraulic System				
System capability	54hp	54hp	54hp	54hp
Pump flow rate	88L 23.2usg	88L 23.2usg	88L 23.2usg	88L 23.2usg
Pump type (Gear / Piston / Helical)	Gear	Gear	Gear	Gear
Pump arrangement (Twin / Tandem Inline)	Twin	Twin	Twin	Twin
Independent hydraulics	●	●	●	●
Oil cooler	○	○	○	○

Kestrel Evo 'S'	5.0m (16'5")	5.0m P (16'5")	5.7m (18'8")	5.7m P (18'8")
Arm features and main frame				
Forward arm	○	○	—	—
Telescopic arm	—	—	—	—
Telescopic arm stroke	—	—	—	—
Power slew	●	●	●	●
Power slew angle	94°	94°	94°	94°
Gravity breakout protection	—	—	—	—
Hydraulic breakout protection	●	●	●	●
Armfloat - manual operation	○	○	○	○
Armfloat - electronic operation	○	○	○	○
Head float - manual operation	●	●	●	●
Head float - electronic operation	○	○	○	○
Left hand cutting	○	○	○	○
Right hand cutting	○	○	○	○
Left and right hand cutting	—	—	—	—
Arm attachments available				
Variable track bracket (VTB)	—	—	—	—
Sheartrim cutter bar	○	○	○	○
Pro-Saw	○	○	○	○
Ditch cleaner	—	—	—	—
Rotary head	○	○	○	○
Accessories				
Road lights	●	●	●	●
Debris blower	○	○	○	○
Cab guard kit	●	●	●	●
Cutting heads (For Flail compatibility see page 97)				
1.2m Pro-Trim with 115/150mm roller	●	●	●	●
1.2m Pro-Trim ISMP with 115/150mm roller	○	○	○	○



Non parallel arm options
Available at request.

Working Reach

Head used for calcs: 1.2 Pro-Trim

	Kestrel Evo 'S' 5.0m (16'5")	Kestrel Evo 'S' 5.0m P (16'5")	Kestrel Evo 'S' 5.7m (18'8")	Kestrel Evo 'S' 5.7m P (18'8")
A	5.05m / 16'7"	4.87m / 15'12"	5.7m / 18'8"	5.7m / 18'8"
B	5.16m / 16'11"	4.94m / 16'3"	5.9m / 19'4"	5.87m / 19'3"
C	3.30m / 10'10"	3.30m / 10'10"	3.86m / 12'8"	4.08m / 13'5"
D	4.42m / 16'6"	3.97m / 13'	5.1m / 16'9"	4.77m / 15'8"
E	6.40m / 20'11"	5.62m / 18'5"	7.11m / 23'4"	6.45m / 21'2"
X	1.3m / 4'1"	1.3m / 4'1"	1.3m / 4'1"	1.3m / 4'1"
Y	1.0m / 3'4"	1.0m / 3'4"	1.0m / 3'4"	1.0m / 3'4"

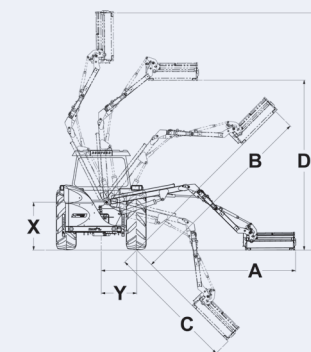

Kestrel Evo Power Plus

Introducing the Kestrel S 5.7P Power Plus. This new model release of the Kestrel now takes this popular reach arm mower to a new level with increased power and additional features.

These features include integral road lighting, tubular 3 point linkage and power slew with hydraulic breakout.

Key Features

- 5.7m reach
- 60hp gear pumps
- Parallel arm standard
- Choice of flails, heads and cutter bars
- Power slew
- Steel hose covers standard



Want to know more about the Kestrel Evo Power Plus range?

Scan the QR code with a smart phone or tablet to instantly view the page.



Power slew and hydraulic breakout
For driver and machine safety.

Steel hose covers
Adding additional protection to drive motor hoses.

Road lights & oil cooler
Fitted as standard.

Product Specification

● Standard ○ Optional — Not Available

Kestrel Evo Power Plus	5.7m (18'8")
Tractor requirements	
Minimum horse power	60hp
Minimum weight	3500kg 7716lbs
Base unit mounting options	
Front mount	○
Mid-mount	—
Rear mount	●
Three point linkage (Cat 11)	●
Axle bracket	—
Sub Frame	—
Yoke	—
Overall machine parameters	
Machine weight with head and oil	1210kg 2268lbs
Capacity of oil tank	160L 42.3usc
Weight of machine with oil but without head	970kg 2139lbs
Controls	
Cable Control (CC)	●
Low pressure hydraulics (LPH)	○
Electronic proportional control (EPP)	○
Intelligent control system (ICS)	●
Cable rotor reverse	—
Electronic rotor reverse	○
Hydraulic System	
System capability	60hp
Pump flow rate	100L 26.4usc
Pump type (Gear / Piston / Helical)	Gear
Pump arrangement (Twin / Tandem Inline)	Twin
Independent hydraulics	●
Oil cooler	○

Kestrel Evo Power Plus	5.7m (18'8")
Arm features and main frame	
Forward arm	—
Telescopic arm	—
Telescopic arm stroke	—
Power slew	●
Power slew angle	94°
Gravity breakout protection	—
Hydraulic breakout protection	●
Armfloat - manual operation	○
Armfloat - electronic operation	○
Head float - manual operation	●
Head float - electronic operation	●
Left hand cutting	○
Right hand cutting	○
Left and right hand cutting	—
Arm attachments available	
Variable track bracket (VTB)	○
Sheartrim cutter bar	○
Pro-Saw	○
Ditch cleaner	—
Rotary head	○
Accessories	
Road lights	●
Debris blower	○
Cab guard kit	●
Cutting heads (For Flail compatibility see 97)	
1.2m Pro-Trim with 115/150mm roller	●
1.2m Pro-Trim ISMP with 115/150mm roller	○



Parallel arm
Available as standard.

Working Reach

Head used for calcs: 1.2 Pro-Trim

	Kestrel Evo Power Plus 5.7m (18'8")
A	5.7m / 18'8"
B	5.9m / 19'4"
C	3.86m / 12'8"
D	5.1m / 16'9"
E	7.11m / 23'4"
X	1.3m / 4'1"
Y	1.0m / 3'4"

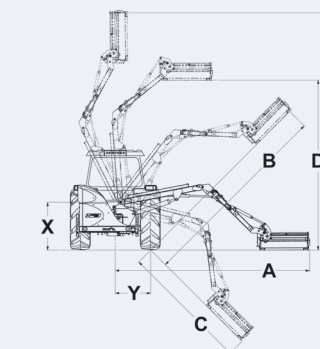

Kestrel Evo 'S' Forward

The ideal choice for the operator with limited tractor size, but requiring the versatility and viewing position of a forward arm.

These features include integral road lighting, tubular 3 point linkage and power slew with hydraulic breakout.

Key Features

- 4.5m and 5m reach
- Forward arm option
- Parallel arm option
- Choice of flails, heads and cutter bars
- Power slew



Want to know more about the Kestrel Evo S Fwd range?

Scan the QR code with a smart phone or tablet to instantly view the page.



Optional oil cooler
Can be fitted in rear panel.

Pro-Trim head
Fitted as standard with top drive motor.

Forward visibility
For ease of operation, forward reach of 600mm / 2'.

Product Specification

● Standard ○ Optional — Not Available

Kestrel Evo 'S' FWD	4.5m (14'10")	5.0m (16'5")
Tractor requirements		
Minimum horse power	50hp	50hp
Minimum weight	3000kg / 6614lbs	3000kg / 6614lbs
Base unit mounting options		
Front mount	—	—
Mid-mount	—	—
Rear mount	●	●
Three point linkage (Cat 11)	●	●
Axle bracket	—	—
Sub Frame	—	—
Yoke	—	—
Overall machine parameters		
Machine weight with head and oil	1180kg / 2601lbs	1180kg / 2601lbs
Capacity of oil tank	160L / 42.3USG	160L / 42.3USG
Weight of machine with oil but without head	940kg / 2072lbs	940kg / 2072lbs
Controls		
Cable Control (CC)	●	●
Low pressure hydraulics (LPH)	○	○
Electronic proportional control (EPP)	○	○
Intelligent control system (ICS)	—	—
Cable rotor reverse	○	○
Electronic rotor reverse	○	○
Hydraulic System		
System capability	54hp	54hp
Pump flow rate	88L / 23.2USG	88L / 23.2USG
Pump type (Gear / Piston / Helical)	Gear	Gear
Pump arrangement (Twin / Tandem Inline)	Twin	Twin
Independent hydraulics	●	●
Oil cooler	○	○

Kestrel Evo 'S' FWD	4.5m (14'10")	5.0m (16'5")
Arm features and main frame		
Forward arm	●	●
Forward arm reach (Fixed / Variable)	600mm / 2'	600mm / 2'
Telescopic arm	—	—
Telescopic arm stroke	—	—
Power slew	●	●
Power slew angle	94°	94°
Gravity breakout protection	—	—
Hydraulic breakout protection	●	●
Arm float - manual operation	○	○
Arm float - electronic operation	○	○
Head float - manual operation	●	●
Head float - electronic operation	○	○
Left hand cutting	○	○
Right hand cutting	○	○
Left and right hand cutting	—	—
Arm attachments available		
Variable track bracket (VTB)	—	—
Sheartrim cutter bar	○	○
Pro-Saw	○	○
Ditch cleaner	—	—
Rotary head	○	○
Accessories		
Road lights	●	●
Debris blower	○	○
Cab guard kit	●	●
Cutting heads (For Flail compatibility see page 97)		
1.2m Pro-Trim with 115/150mm roller	●	●
1.2m Pro-Trim ISMP with 115/150mm roller	○	○

Reach great heights
With forward positioning and two reach options of 4.5m and 5.0m.

Working Reach

Head used for calcs: 1.2 Pro-Trim

	Kestrel Evo 'S' Forward 4.5m (14'10")	Kestrel Evo 'S' Forward 5.0m (16'5")
A	4.53m / 14'10"	4.97m / 16'4"
B	4.64m / 15'3"	5.07m / 16'8"
C	2.64m / 8'8"	3.23m / 10'7"
D	4.05m / 13'3"	4.48m / 14'8"
E	5.83m / 19'2"	6.33m / 20'9"
X	1.33m / 4'1"	1.33m / 4'1"
Y	1.0m / 3'4"	1.0m / 3'4"

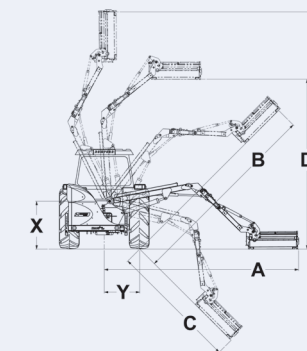

Kestrel Evo 'S' VFA

The ever popular VFA variable forward arm is now available in the compact yet powerful Kestrel 'S' range.

Features include integral road lighting, tubular 3 point linkage and power slew with hydraulic breakout.

Key Features

- 5m and 5.7m reach
- Parallel arm as standard
- Choice of flails, heads and cutter bars
- Power slew
- Debris blower option



Want to know more about the Kestrel Evo S VFA range?

Scan the QR code with a smart phone or tablet to instantly view the page.



Low profile tank

Aids driver visibility.

LED road lighting

Fitted as standard.

Powerful 74hp hydraulics

For continuous use. Twin pumps with separate oil tank.

Product Specification

● Standard ○ Optional — Not Available

Kestrel Evo 'S' VFA	5.0m (16'5")	5.7m (18'8")
Tractor requirements		
Minimum horse power	50hp	50hp
Minimum weight	3000kg / 6614lbs	3000kg / 6614lbs
Base unit mounting options		
Front mount	—	—
Mid-mount	—	—
Rear mount	●	●
Three point linkage (Cat 11)	●	●
Axle bracket	—	—
Sub Frame	—	—
Yoke	—	—
Overall machine parameters		
Machine weight with head and oil	1180kg / 2601lbs	1380kg / 3042lbs
Capacity of oil tank	160L / 42.3USG	160L / 42.3USG
Weight of machine with oil but without head	940kg / 2072lbs	1140kg / 2513lbs
Controls		
Cable Control (CC)	●	●
Low pressure hydraulics (LPH)	○	○
Electronic proportional control (EPP)	○	○
Intelligent control system (ICS)	—	—
Cable rotor reverse	●	●
Electronic rotor reverse	○	○
Hydraulic System		
System capability	54hp	54hp
Pump flow rate	88L / 19.4USG	88L / 19.4USG
Pump type (Gear / Piston / Helical)	Gear	Gear
Pump arrangement (Twin / Tandem Inline)	Twin	Twin
Independent hydraulics	●	●
Oil cooler	○	○

Kestrel Evo 'S' VFA	5.0m (16'5")	5.7m (18'8")
Arm features and main frame		
Forward arm	1200mm / 3'11"	1200mm / 3'11"
Telescopic arm	—	—
Telescopic arm stroke	—	—
Power slew	●	●
Power slew angle	94°	94°
Gravity breakout protection	—	—
Hydraulic breakout protection	●	●
Arm float - manual operation	○	○
Arm float - electronic operation	○	○
Head float - manual operation	●	●
Head float - electronic operation	○	○
Left hand cutting	○	○
Right hand cutting	○	○
Left and right hand cutting	—	—
Arm attachments available		
Variable track bracket (VTB)	—	—
Sheartrim cutter bar	○	○
Pro-Saw	○	○
Ditch cleaner	—	—
Rotary head	○	○
Accessories		
Road lights	●	●
Debris blower	○	○
Cab guard kit	●	●
Cutting heads (For Flail compatibility see page 97)		
1.2m Pro-Trim with 115/150mm roller	●	●
1.2m Pro-Trim ISMP with 115/150mm roller	○	○
1.5m Pro-Trim with 115/150mm roller	○	○

Clear visibility

Variable forward reach brings cutting head into drivers view.

Working Reach

Head used for calcs: 1.2 Pro-Trim

Side Reach		
	Kestrel Evo 'S' VFA 5.0M (16'5")	Kestrel Evo 'S' VFA 5.7M (18'8")
A	5.08m / 16'8"	5.76m / 18'11"
B	4.80m / 15'9"	5.50m / 18'
C	4.94m / 16'2"	5.64m / 18'6"
D	4.49m / 14'9"	5.19m / 17'
E	5.66m / 18'7"	6.36m / 20'10"
X	1.35m / 4'5"	1.35m / 4'5"
Y	1.0m / 3'4"	1.0m / 3'4"

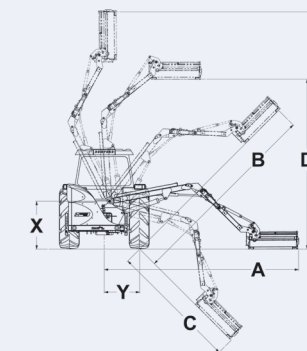

Forward Reach		
	Kestrel Evo 'S' VFA 5.0M (16'5")	Kestrel Evo 'S' VFA 5.7M (18'8")
A	5.08m / 16'8"	5.76m / 18'11"
F	4.96m / 17'8"	5.66m / 18'7"
G	5.0m / 16'4"	5.7m / 18'8"
H	1.2m / 3'11"	1.2m / 3'11"
J	0.56m / 1'10"	0.56m / 1'10"

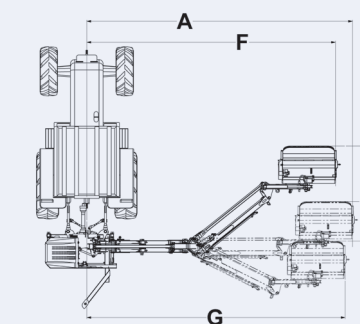

Kestrel Evo 'S' Front Mounted

The Kestrel Evo 'S' Front Mounted offers a dedicated designed front mounted machine, fitted with hydraulic break out and power slew as standard.

These features include integral road lighting, tubular 3 point linkage and power slew with hydraulic breakout.

Key Features

- 5.0m reach
- Front mount option
- Choice of flails, heads and cutter bars
- Power slew



Want to know more about the Kestrel Evo S FM range?

Scan the QR code with a smart phone or tablet to instantly view the page.

Product Specification

● Standard ○ Optional — Not Available

Kestrel Evo 'S' FM	5.0m (16'5")
Tractor requirements	
Minimum horse power	50hp
Minimum weight	3000kg / 6614lbs
Base unit mounting options	
Front mount	●
Mid-mount	—
Rear mount	—
Three point linkage (Cat 11)	●
Axle bracket	—
Sub Frame	—
Yoke	—
Overall machine parameters	
Machine weight with head and oil	1180kg / 2601lbs
Capacity of oil tank	160L / 42.3USG
Weight of machine with oil but without head	940kg / 2072lbs
Controls	
Cable Control (CC)	—
Low pressure hydraulics (LPH)	—
Electronic proportional control (EPP)	—
Intelligent control system (ICS)	●
Cable rotor reverse	○
Electronic rotor reverse	●
Hydraulic System	
System capability	60hp
Pump flow rate	104L / 27.5USG
Pump type (Gear / Piston / Helical)	Gear
Pump arrangement (Twin / Tandem Inline)	Twin
Independent hydraulics	●
Oil cooler	●

Kestrel Evo 'S' FM	5.0m (16'5")
Arm features and main frame	
Forward arm	—
Forward arm reach (Fixed / Variable)	—
Telescopic arm	—
Telescopic arm stroke	—
Power slew	●
Power slew angle	94°
Gravity breakout protection	—
Hydraulic breakout protection	●
Arm float - manual operation	○
Arm float - electronic operation	○
Head float - manual operation	●
Head float - electronic operation	○
Left hand cutting	○
Right hand cutting	○
Left and right hand cutting	—
Arm attachments available	
Variable track bracket (VTB)	—
Sheartrim cutter bar	○
Pro-Saw	○
Ditch cleaner	—
Rotary head	—
Accessories	
Road lights	●
Debris blower	—
Cab guard kit	●
Cutting heads (For Flail compatibility see page 97)	
1.2m Pro-Trim with 115/150mm roller	●
1.2m Pro-Trim ISMP with 115/150mm roller	○
1.5m Pro-Trim with 115/150mm roller	○



ICS Control system
For ease of use and mounting.

Low profile tank
Aids driver visibility.

Forward facing road lights
Fitted as standard.

Covered hydraulics
A powerful 104 litre system creating 60hp.

Working Reach

Head used for calcs: 1.2 Pro-Trim

Kestrel Evo 'S' Front Mounted 5.0M (16'5")	
A	5.05m / 16'7"
B	5.16m / 16'11"
C	3.30m / 10'10"
D	4.42m / 14'6"
E	6.40m / 21'
X	1.3m / 4'1"
Y	1.0m / 3'4"

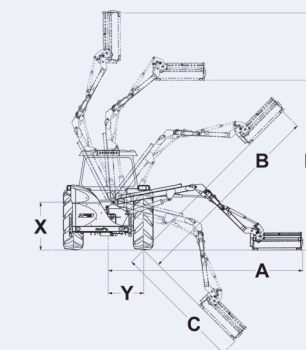

Hawk Evo

The Hawk Evo is perfect for farmers, contractors and municipal environments.

Fitted with a powerful 104 litre drive system, and options to upgrade to 125 litre, the Hawk Evo offers a machine for every application.

Key Features

- 5.4m, 6.0m, 6.5m or 7.0m reach
- 1.2m Pro-Trim head or 1.5m option
- 104 l/min independent hydraulic system
- 125 l/min standard on 6.5m and 7.0m models
- 94° of slew (max non parallel systems)



Want to know more about the Hawk Evo range?

Scan the QR code with a smart phone or tablet to instantly view the page.



Fully enclosed hydraulics
Keeping components protected.

Oil cooler
Standard on all models (cable controls as an option).

Road lights
Fitted as standard.

Product Specification

● Standard ○ Optional — Not Available

Hawk Evo	5.4m P (17'9")	6.0m P (19'8")	6.5m P (21'4")	7.0m P (22'11")
Tractor requirements				
Minimum horse power	65hp	65hp	65hp	80hp
Minimum weight	4500kg 9921lbs	5000kg 11023lbs	5500kg 12125lbs	5500kg 12125lbs
Base unit mounting options				
Front mount	—	—	—	—
Mid-mount	—	—	—	—
Rear mount	●	●	●	●
Three point linkage (Cat 11)	●	●	●	●
Axle bracket	○	○	○	○
Overall machine parameters				
Machine weight with head and oil	1340kg 2954lbs	1490kg 3285lbs	1740kg 3836lbs	1780kg 3924lbs
Capacity of oil tank	180L 47.6USG	180L 47.6USG	200L 52.8USG	200L 52.8USG
Weight of machine with oil but without head	1100kg 2425lbs	1250kg 2756lbs	1500kg 3307lbs	1540kg 3395lbs
Controls				
Cable Control (CC)	●	●	●	●
Low pressure hydraulics (LPH)	○	○	○	○
Electronic proportional control (EPP)	○	○	○	○
Intelligent control system (ICS)	○	○	○	○
Cable rotor reverse	○	○	○	○
Electronic rotor reverse	○	○	○	○
Hydraulic System				
System capability	60hp	60hp	74hp	74hp
Pump flow rate	104L 27.5USG	104L 27.5USG	125L 33USG	125L 33USG
Pump type (Gear / Piston / Helical)	Gear	Gear	Gear	Gear
Pump arrangement (Twin / Tandem inline)	Twin	Twin	Twin	Twin
Independent hydraulics	●	●	●	●
Oil cooler	○	○	○	○

Hawk Evo	5.4m P (17'9")	6.0m P (19'8")	6.5m P (21'4")	7.0m P (22'11")
Arm features and main frame				
Telescopic arm	—	—	●	●
Telescopic arm stroke	—	—	900mm 3'	900mm 3'
Power slew	●	●	●	●
Power slew angle	94°	94°	94°	94°
Gravity breakout protection	—	—	—	—
Hydraulic breakout protection	●	●	●	●
Arm float - manual operation	○	○	○	○
Arm float - electronic operation	○	○	○	○
Head float - manual operation	●	●	●	●
Head float - electronic operation	○	○	○	○
Left hand cutting	○	○	○	○
Right hand cutting	○	○	○	○
Left and right hand cutting	—	—	—	—
Arm attachments available				
Variable track bracket (VTB)	—	—	—	—
Sheartrim cutter bar	○	○	○	○
Pro-Saw	○	○	○	○
Ditch cleaner	○	○	○	○
Rotary head	○	○	○	○
Accessories				
Road lights	●	●	●	●
Debris blower	○	○	○	○
Cab guard kit	●	●	●	●
Cutting heads (For Flail compatibility see page 97)				
1.2m Pro-Trim with 115/150mm roller	●	●	●	●
1.2m Pro-Trim ISMP with 115/150mm roller	○	○	○	○
1.5m Pro-Trim with 115/150mm roller	○	○	○	○



Slimline compact transport position
Keeping weight closer to tractor for faster road speeds.

Working Reach

Head used for calcs: 1.2 Pro-Trim

	Hawk Evo 5.4m P (17'9")	Hawk Evo 6.0m P (19'8")	Hawk Evo 6.5m P (21'4")	Hawk Evo 7.0m P (22'11")
A	5.35m / 17'7"	5.95m / 19'6"	6.47m / 21'3"	6.96m / 22'10"
B	5.39m / 17'8"	6.11m / 20'1"	6.21m / 20'11"	6.74m / 22'1"
C	3.64m / 11'11"	4.32m / 14'2"	4.68m / 15'4"	4.37m / 14'4"
D	4.25m / 13'11"	4.74m / 15'7"	4.97m / 16'4"	5.67m / 18'7"
E	5.89m / 19'4"	6.39m / 21'	6.62m / 21'9"	7.67m / 22'11"
X	1.35m / 4'5"	1.35m / 4'5"	1.35m / 4'5"	1.35m / 4'5"
Y	1.0m / 3'4"	1.0m / 3'4"	1.0m / 3'4"	1.0m / 3'4"

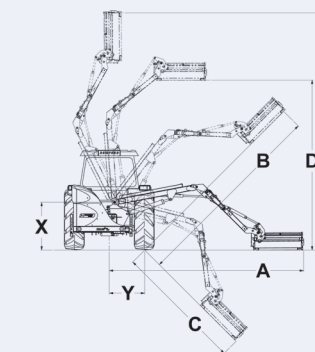

Hawk Evo Power Plus

The Hawk Evo Power Plus is perfect for contractors and municipal environments.

These features include integral road lighting, tubular 3 point linkage and power slew with hydraulic breakout.

Key Features

- 6.5m and 7.0m reach options
- Parallel arm standard
- Steel hose covers
- Choice of flails, heads and cutter bars
- Power slew
- Oil cooler standard



Want to know more about the Hawk Evo Power Plus range?

Scan the QR code with a smart phone or tablet to instantly view the page.



Steel hose covers
Adding additional protection to drive motor houses.

Parallel arm geometry
Available as standard.

Road lights
Fitted as standard.

Product Specification

● Standard ○ Optional — Not Available

Hawk Evo Power Plus	6.5m P (21'4")	7.0m P (23')
Tractor requirements		
Minimum horse power	100hp	100hp
Minimum weight	5500kg 12125lbs	5500kg 12125lbs
Base unit mounting options		
Front mount	—	—
Mid-mount	—	—
Rear mount	●	●
Three point linkage (Cat 11)	●	●
Axle bracket	○	○
Overall machine parameters		
Machine weight with head and oil	1740kg 3836lbs	1780kg 3924lbs
Capacity of oil tank	200L 52.8USG	200L 52.8USG
Weight of machine with oil but without head	1500kg 3307lbs	1540kg 3395lbs
Controls		
Cable Control (CC)	—	—
Low pressure hydraulics (LPH)	—	—
Electronic proportional control (EPP)	—	—
Intelligent control system (ICS)	●	●
Cable rotor reverse	○	○
Electronic rotor reverse	○	○
Hydraulic System		
System capability	74hp	74hp
Pump flow rate	125L 33USG	125L 33USG
Pump type (Gear / Piston / Helical)	Gear	Gear
Pump arrangement (Twin / Tandem Inline)	Twin	Twin
Independent hydraulics	●	●
Oil cooler	○	○

Hawk Evo Power Plus	6.5m P (21'4")	7.0m P (23')
Arm features and main frame		
Telescopic arm	●	●
Telescopic arm stroke	900mm 3'	900mm 3'
Power slew	●	●
Power slew angle	94°	94°
Gravity breakout protection	—	—
Hydraulic breakout protection	●	●
Arm float - manual operation	○	○
Arm float - electronic operation	○	○
Head float - manual operation	○	○
Head float - electronic operation	●	●
Left hand cutting	○	○
Right hand cutting	○	○
Left and right hand cutting	—	—
Arm attachments available		
Variable track bracket (VTB)	—	—
Sheartrim cutter bar	○	○
Pro-Saw	○	○
Ditch cleaner	○	○
Rotary head	○	○
Accessories		
Road lights	●	●
Debris blower	○	○
Cab guard kit	●	●
Cutting heads (For Flail compatibility see page 97)		
1.2m Pro-Trim with 115/150mm roller	●	●
1.2m Pro-Trim ISMP with 115/150mm roller	○	○
1.5m Pro-Trim with 115/150mm roller	○	○



Oil cooler as standard
High level keeping clear of any cutting debris.

Working Reach

Head used for calcs: 1.2 Pro-Trim

	Hawk Evo 6.5m P (21'4")	Hawk Evo 7.0m P (23')
A	6.47m / 21'3"	7.03m / 23'1"
B	6.21m / 20'11"	6.91m / 22'8"
C	4.68m / 15'4"	4.83m / 15'10"
D	4.97m / 16'4"	5.69m / 18'8"
E	6.62m / 21'9"	7.40m / 24'3"
X	1.35m / 4'5"	1.35m / 4'5"
Y	1.0m / 3'4"	1.0m / 3'4"

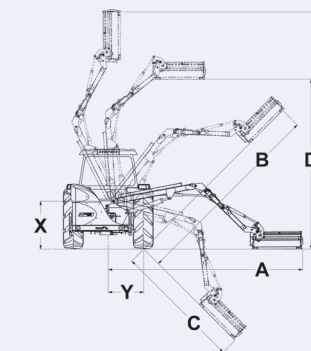

Hawk Evo Forward

The Hawk Evo Forward arm is perfect for farmers, contractors and municipal environments where the added benefits of a forward arm is required to improve visibility and minimise operator stress and fatigue.

Fitted as standard with the powerful 125 litre drive system, the Hawk Evo Forward will perform on all stages. There is a choice of controls and attachments to suit a wide range of applications.

Key Features

- 5.4m or 6.0m reach
- Heavy duty linkage
- 125 l/min independent system
- 1.2m or 1.5m cutting head
- Non parallel



Want to know more about the Hawk Evo Fwd range?

Scan the QR code with a smart phone or tablet to instantly view the page.



Folding second arm

Hydraulic arm folds to create a narrow width to aid transport.



Heavy duty linkage

Provide maximum stability for larger arm mowers.



Oil cooler

Standard on all models (cable controls as an option).

Product Specification

● Standard ○ Optional — Not Available

Hawk Evo FWD	5.4m (17'9")	6.0m (19'8")
Tractor requirements		
Minimum horse power	65hp	70hp
Minimum weight	4500kg/992lbs	5000kg/11023lbs
Base unit mounting options		
Front mount	—	—
Mid-mount	—	—
Rear mount	●	●
Three point linkage (Cat 11)	●	●
Axle bracket	○	○
Overall machine parameters		
Machine weight with head and oil	1640kg/3616lbs	1740kg/3836lbs
Capacity of oil tank	200L/53USG	200L/53USG
Weight of machine with oil but without head	1400kg/3086lbs	1500kg/3307lbs
Controls		
Cable Control (CC)	●	●
Low pressure hydraulics (LPH)	○	○
Electronic Switch Control (ESC)	○	○
Electronic proportional control (EPP)	○	○
Intelligent control system (ICS)	○	○
Cable rotor reverse	○	○
Electronic rotor reverse	○	○
Hydraulic System		
System capability	74hp	74hp
Pump flow rate	125L/ 33USG	125L/ 33USG
Pump type (Gear / Piston / Helical)	Gear	Gear
Pump arrangement (Twin / Tandem Inline)	Twin	Twin
Independent hydraulics	●	●
Oil cooler	○	○
Accessories		
Road lights	●	●
Debris blower	○	○
Cab guard kit	●	●

Hawk Evo FWD	5.4m (17'9")	6.0m (19'8")
Arm features and main frame		
Forward reach arm	●	●
Forward reach	800mm / 2'6"	800mm / 2'6"
Power slew	●	●
Power slew angle	94°	94°
Gravity breakout protection	—	—
Hydraulic breakout protection	●	●
Arm float - manual operation	○	○
Arm float - electronic operation	○	○
Head float - manual operation	●	●
Head float - electronic operation	○	○
Left hand cutting	○	○
Right hand cutting	○	○
Left and right hand cutting	—	—
Arm attachments available		
Variable track bracket (VTB)	—	—
Sheartrim cutter bar	○	○
Pro-Saw	○	○
Ditch cleaner	○	○
Rotary head	○	○
Cutting heads (For Flail compatibility see page 97)		
1.2m Pro-Trim with 115/150mm roller	●	●
1.2m Pro-Trim ISMP with 115/150mm roller	○	○
1.5m Pro-Trim with 115/150mm roller	○	○



Optimum viewing position

Clearly see the operation of the cutting head and manoeuvre around obstacles.

Working Reach

Head used for calcs: 1.2 Pro-Trim

	Hawk Evo FWD 5.4m (17'9")	Hawk Evo FWD 6.0m (19'8")
A	5.36m / 17'7"	5.96m / 19'7"
B	5.52m / 18'1"	6.08m / 19'11"
C	3.50m / 11'6"	4.21m / 13'10"
D	4.87m / 16'	5.19m / 17'
E	6.65m / 21'10"	7.27m / 23'8"
X	1.35m / 4'5"	1.35m / 4'5"
Y	1.00m / 3'4"	1.00m / 3'4"

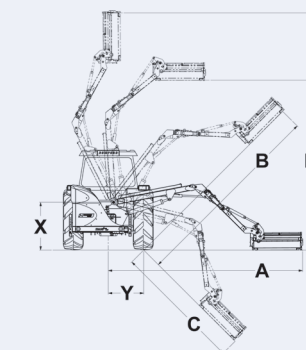

Hawk Evo VFA

The Hawk Evo VFA (Variable Forward Arm) is perfect for contractors and municipal environments, where the added benefits of a forward arm is required to improve visibility.

With a maximum reach of 6m, the Hawk Evo VFA can cope with every job it is tasked with. The impressive 1.8m maximum travel on the variable forward arm (VFA) gives 1.6m forward working.

Key Features

- 6.0m reach
- Over 1.8m traverse on variable forward arm
- Heavy duty linkage or axle bracket mounted
- 125 l/min independent system



Want to know more about the Hawk Evo VFA range?

Scan the QR code with a smart phone or tablet to instantly view the page.



Transport bracket
Supplied as standard for fast travelling on the road.



Massive 1.6m forward reach
For optimum viewing position when working.



Clear visibility
Variable forward reach brings cutting head into drivers view.

Product Specification

● Standard ○ Optional — Not Available

Hawk Evo VFA	6.0m (19'8")
Tractor requirements	
Minimum horse power	80hp
Minimum weight	5000kg/11023lbs
Base unit mounting options	
Front mount	—
Mid-mount	—
Rear mount	●
Three point linkage (Cat 11)	●
Axle bracket	○
Overall machine parameters	
Machine weight with head and oil	1860kg/4100lbs
Capacity of oil tank	200L/ 52.8USG
Weight of machine with oil but without head	1600kg/ 3527lbs
Controls	
Cable Control (CC)	●
Low pressure hydraulics (LPH)	○
Electronic proportional control (EPP)	○
Intelligent control system (ICS)	○
Cable rotor reverse	●
Electronic rotor reverse	○
Hydraulic System	
System capability	74hp
Pump flow rate	125L/ 33USG
Pump type (Gear / Piston / Helical)	Gear
Pump arrangement (Twin / Tandem Inline)	Twin
Independent hydraulics	●
Oil cooler	●

Hawk Evo VFA	6.0m (19'8")
Arm features and main frame	
Forward arm	1600mm / 5'3"
Telescopic arm	—
Telescopic arm stroke	—
Power slew	●
Power slew angle	94°
Gravity breakout protection	—
Hydraulic breakout protection	●
Arm float - manual operation	○
Arm float - electronic operation	○
Head float - manual operation	○
Head float - electronic operation	●
Left hand cutting	○
Right hand cutting	○
Left and right hand cutting	—
Arm attachments available	
Variable track bracket (VTB)	○
Sheartrim cutter bar	○
Pro-Saw	○
Ditch cleaner	○
Rotary head	○
Accessories	
Road lights	●
Debris blower	○
Cab guard kit	●
Cutting heads (For Flail compatibility see page 97)	
1.2m Pro-Trim head with 115/150mm roller	●
1.5m Pro-Trim head with 115/150mm roller	○
1.2m Pro-Trim ISMP with 115mm roller	○
1.2m Pro-Cut head with 115/150mm roller	○
1.5m Pro-Cut head with 115/150mm roller	○
1.2m Pro-Cut ISMP with 150mm roller	○



Variable Forward Arm
The VFA allows total flexibility of position during arms operation.

Working Reach

Head used for calcs: 1.2m Pro-Trim

Side Reach Hawk Evo 6.0 VFA (19'8")	
A	6.0m / 19'8"
B	5.96m / 19'7"
C	4.18m / 13'9"
D	4.99m / 16'5"
E	6.16m / 20'3"
X	1.35m / 4'5"
Y	1.00m / 3'4"

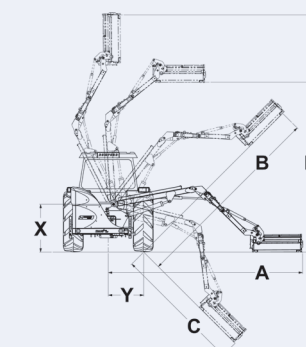

Forward Reach Hawk Evo 6.0 VFA (19'8")	
A	6.0m / 19'8"
F	5.39m / 17'8"
G	5.9m / 19'4"
H	1.6m / 5'3"
J	0.56m / 1'10"

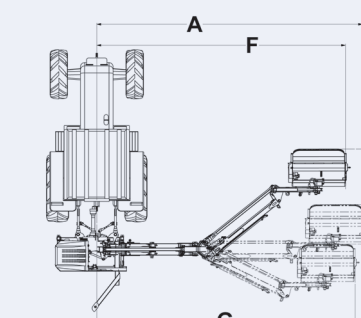

Falcon Evo

The Falcon Evo range has been specifically designed for the large scale contractor.

With high specification options and a range of controls to select from, the Falcon range is the first choice for contractors.

Key Features

- 5.5m, 6.0m or 6.5m reach
- Heavy duty linkage
- 125 l/min independent system
- 1.2m or 1.5m cutting head
- Parallel option



Want to know more about the Falcon Evo range?

Scan the QR code with a smart phone or tablet to instantly view the page.



Pressed steel first arm construction

Strength and weight-saving without compromise.

Oil cooler

Standard on all models (cable controls as an option).

125L and 74HP pumps

Comes as standard, with 137L and 85HP options.

Product Specification

● Standard ○ Optional — Not Available

Falcon Evo	5.5m (18'1")	6.0m T (19'8")	6.5m T (21'4")	Bi-Way 5.5 (18'1")
Tractor requirements				
Minimum horse power	75hp	75hp	75hp	75hp
Minimum weight	4500kg 9921lbs	5000kg 11023lbs	5500kg 12125lbs	5500kg 12125lbs
Base unit mounting options				
Front mount	—	—	—	○
Mid-mount	—	—	—	—
Rear mount	●	●	●	●
Three point linkage (Cat 11)	●	●	○	●
Axle bracket	○	○	●	○
Overall machine parameters				
Machine weight with head and oil	1790kg 3946lbs	1890kg 4167lbs	2190kg 4828lbs	1930kg 4255lbs
Capacity of oil tank	250L 66USG	250L 66USG	250L 66USG	250L 66USG
Weight of machine with oil but without head	1500kg 3307lbs	1600kg 3527lbs	1900kg 4189lbs	1640kg 3616lbs
Controls				
Cable Control (CC)	●	●	●	●
Low pressure hydraulics (LPH)	○	○	○	○
Electronic proportional control (EPP)	○	○	○	○
Intelligent control system (ICS)	○	○	○	○
Cable rotor reverse	○	○	○	○
Electronic rotor reverse	○	○	○	○
Hydraulic system				
System capability	74hp	74hp	74hp	74hp
Pump flow rate	125L 33USG	125L 33USG	125L 33USG	125L 33USG
Pump type (Gear/Piston/Helical)	Gear	Gear	Gear	Gear
Pump arrangement (Twin/In-line)	Twin	Twin	Twin	Twin
Independent hydraulics	●	●	●	●
Oil cooler	○	○	○	○

Falcon Evo	5.5m (18'1")	6.0m T (19'8")	6.5m T (21'4")	Bi-Way 5.5 (18'1")
Arm features and main frame				
Forward arm	—	—	—	—
Forward arm reach	—	—	—	—
Telescopic arm	—	●	●	—
Telescopic arm stroke	—	900mm 3'	900mm 3'	—
Power slew	●	—	—	●
Power slew angle	94°	94°	94°	94°
Gravity breakout protection	—	—	—	—
Hydraulic breakout protection	●	●	●	●
Arm float - manual operation	○	○	○	○
Arm float - electronic operation	○	○	○	○
Head float - manual operation	●	●	●	●
Head float - electronic operation	○	○	○	○
Left hand cutting	○	○	○	○
Right hand cutting	○	○	○	○
Left and right hand cutting	—	—	—	—
Arm attachments available				
Variable track bracket (VTB)	○	○	○	—
Sheartrim cutter bar	○	○	○	○
Pro-Saw	○	○	○	○
Ditch cleaner	○	○	○	—
Rotary head	○	○	○	—
Accessories				
Road Lights	●	●	●	●
Debris Blower	○	○	○	○
Cab Guard Kit	●	●	●	●
Cutting heads (For Flail compatibility see page 97)				
1.2m Pro-Cut - 115/150mm roller	●	●	●	●
1.5m Pro-Cut - 115/150mm roller	○	○	○	○
1.2m Pro-Cut ISMP - 115/150mm roller	○	○	○	○
2m HD head	○	○	○	○



Bi-Way arm options

Allows the machine to cut in both forward and reverse directions.

Working Reach

Head used for calcs: 1.2 Pro-Cut

	Falcon 5.5m (18'1")	Falcon 6.0m T (19'8")	Falcon 6.5m T (21'4")	Falcon Bi-Way 5.5m (18'1")
A	5.54m/18'2"	6.07m/19'11"	6.42m/21'1"	5.72m/18'9"
B	5.69m/18'8"	6.22m/20'5"	6.74m/22'1"	5.82m/19'1"
C	3.49m/11'5"	4.42m/14'6"	4.10m/13'11"	3.86m/12'8"
D	4.42m/14'6"	4.54m/14'11"	5.65m/18'6"	4.74m/15'7"
E	6.06m/19'	6.18m/20'3"	7.67m/25'2"	6.92m/22'8"
X	1.35m/4'5"	1.35m/4'5"	1.35m/4'5"	1.35m/4'5"
Y	1.0m/3'4"	1.0m/3'4"	1.0m/3'4"	1.0m/3'4"

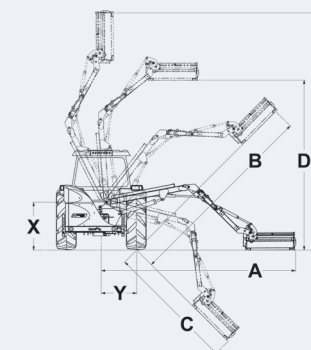

Falcon Evo Forward

The Falcon Evo Forward arm is perfect for contractors and municipal environments, where the added benefits of a forward arm is required to improve visibility.

With high specification options and a range of controls to select from, the Falcon range is first choice for contractors.

Key Features

- 5.5m or 6.0/6.5m telescopic reach
- Fixed forward reach of 1.2m
- Heavy duty linkage on 5.5 or axle bracket mounted on 6.0 & 6.5
- 125 l/min independent system
- 1.2m or 1.5m cutting head



Want to know more about the Falcon Evo Fwd range?

Scan the QR code with a smart phone or tablet to instantly view the page.



Telescopic 3rd arm on 6.0T and 6.5T models
Gives increased flexibility.



Excellent reach characteristics
Enables cutting in challenging environments.

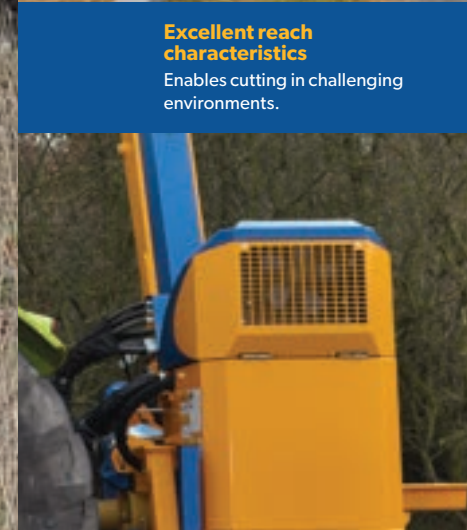

Oil cooler
Standard on all models (cable controls as an option).

Product Specification

● Standard ○ Optional — Not Available

Falcon Evo FWD	FWD 5.5 (18'1")	FWD 6.0T (19'8")	FWD 6.5T (21'4")
Tractor requirements			
Minimum horse power	100hp	120hp	120hp
Minimum weight	4500kg 9921lbs	5000kg 11023lbs	5500kg 12125lbs
Base unit mounting options			
Front mount	—	—	—
Mid-mount	—	—	—
Rear mount	●	●	●
Three point linkage (Cat 11)	●	●	—
Axle bracket	○	○	○
Overall machine parameters			
Machine weight with head and oil	1990kg 4387lbs	2190kg 4828lbs	2245kg 4950lbs
Capacity of oil tank	250L 66USG	250L 66USG	250L 66USG
Weight of machine with oil but without head	1700kg 3748lbs	1900kg 4189lbs	1955kg 4310lbs
Controls			
Cable Control (CC)	●	●	●
Low pressure hydraulics (LPH)	—	—	—
Electronic proportional control (EPP)	○	○	○
Intelligent control system (ICS)	○	○	○
Cable rotor reverse	●	●	●
Electronic rotor reverse	○	○	○
Hydraulic system			
System capability	74hp	74hp	74hp
Pump flow rate	125L 33USG	125L 33USG	125L 33USG
Pump type (Gear/Piston/Helical)	Gear	Gear	Gear
Pump arrangement (Twin/In-line)	Twin	Twin	Twin
Independent hydraulics	●	●	●
Oil cooler	●	●	●

Falcon Evo FWD	FWD 5.5 (18'1")	FWD 6.0T (19'8")	FWD 6.5T (21'4")
Arm features and main frame			
Forward arm	1200mm 3'11"	1200mm 3'11"	1200mm 3'11"
Telescopic arm	●	●	●
Telescopic arm stroke	—	900mm 3'	900mm 3'
Power slew	●	●	●
Power slew angle	94°	94°	94°
Gravity breakout protection	—	—	—
Hydraulic breakout protection	●	●	●
Arm float - manual operation	●	●	●
Arm float - electronic operation	○	○	○
Head float - manual operation	○	○	○
Head float - electronic operation	○	○	○
Left hand cutting	○	○	○
Right hand cutting	○	○	○
Left and right hand cutting	—	—	—
Arm attachments available			
Variable track bracket (VTB)	—	—	—
Sheartrim cutter bar	○	○	○
Pro-Saw	○	○	○
Ditch cleaner	○	○	○
Rotary head	○	○	○
Accessories			
Road Lights	●	●	●
Debris Blower	○	○	○
Cab Guard Kit	●	●	●
Cutting heads (For Flail compatibility see page 97)			
1.2m Pro-Cut - 115/150mm roller	●	●	●
1.5m Pro-Cut - 115/150mm roller	○	○	○
1.2m Pro-Cut ISMP - 115/150mm roller	○	○	○
2m HD head	○	○	○



Transport bracket
Supplied as standard for fast travelling on the road.

Working Reach

Head used for calcs: 1.2 Pro-Cut

	Falcon Evo FWD 5.5m (18'1")	Falcon Evo FWD 6.0m T (19'8")	Falcon Evo FWD 6.5m T (21'4")
A	5.58m/18'4"	6.1m/20'	6.55m/21'6"
B	5.73m/18'10"	6.45m/21'2"	6.71m/22'
C	3.62m/11'11"	4.68m/15'4"	4.90m/16'11"
D	4.99m/16'5"	5.45m/17'11"	5.73m/18'10"
E	6.83m/22'5"	7.56m/24'10"	7.79m/25'7"
X	1.35m/4'9"	1.35m/4'9"	1.35m/4'9"
Y	1.0m/3'4"	1.0m/3'4"	1.0m/3'4"

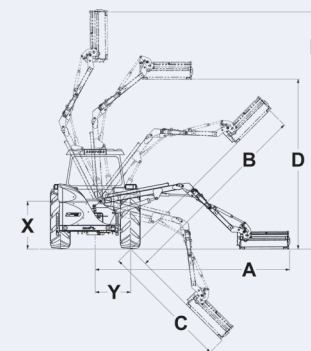

Falcon Evo VFA

The Falcon Evo VFA (Variable Forward Arm) is perfect for contractors and municipal environments, where the added benefits of a forward arm is required to improve visibility.

This flagship model in the VFA range provides an unrivalled 2.1m total travel including 1.8m forward reach, resulting in an optimum mid-mounted cutting head position.

Key Features

- 6.5m reach
- Over 2m traverse on variable forward arm
- Axle bracket mounted only
- 125 l/min independent system



Want to know more about the Falcon Evo VFA range?

Scan the QR code with a smart phone or tablet to instantly view the page.



Arm float cylinder
To aid grass cutting on roadsides.



Forward reach position
Enables mid-mounted head position with simplicity of rear mounted arm.



Parallel linkage
Comes as standard to assist operator control.

Product Specification

● Standard ○ Optional — Not Available

Falcon Evo VFA	VFA 6.5m P (21'4")
Tractor requirements	
Minimum horse power	120hp
Minimum weight	5500kg / 12125lbs
Base unit mounting options	
Front mount	—
Mid-mount	—
Rear mount	●
Three point linkage (Cat 11)	—
Axle bracket	●
Overall machine parameters	
Machine weight with head and oil	2270kg / 5005lbs
Capacity of oil tank	250L / 66USG
Weight of machine with oil but without head	1980kg / 4365lbs
Controls	
Cable Control (CC)	●
Low pressure hydraulics (LPH)	—
Electronic proportional control (EPP)	○
Intelligent control system (ICS)	○
Cable rotor reverse	○
Electronic rotor reverse	○
Hydraulic system	
System capability	74hp
Pump flow rate	125L / 33USG
Pump type (Gear/Piston/Helical)	Gear
Pump arrangement (Twin/In-line)	Twin
Independent hydraulics	●
Oil cooler	●

Falcon Evo VFA	VFA 6.5m P (21'4")
Arm features and main frame	
Forward arm	1816mm / 6'
Telescopic arm	—
Telescopic arm stroke	—
Power slew	●
Power slew angle	94°
Gravity breakout protection	—
Hydraulic breakout protection	●
Arm float - manual operation	○
Arm float - electronic operation	○
Head float - manual operation	●
Head float - electronic operation	○
Left hand cutting	○
Right hand cutting	○
Left and right hand cutting	—
Arm attachments available	
Variable track bracket (VTB)	—
Sheartrim cutter bar	○
Pro-Saw	○
Ditch cleaner	○
Rotary head	○
Accessories	
Road Lights	●
Debris Blower	○
Cab Guard Kit	●
Cutting heads (For Flail compatibility see page 97)	
1.2m Pro-Cut - 115/150mm roller	●
1.5m Pro-Cut - 115/150mm roller	○
1.2m Pro-Cut ISMP - 115/150mm roller	○
2m HD head	○



Variable Forward Arm
The VFA allows total flexibility of position during arms operation.

Working Reach

Head used for calcs: 1.2m Pro-Cut

Side Reach Falcon Evo 6.5m P VFA (21'4")	
A	6.5m / 21'4"
B	6.83m / 22'5"
C	4.61m / 15'2"
D	6.03m / 18'9"
E	7.66m / 25'2"
X	1.6m / 5'3"
Y	1.00m / 3'4"

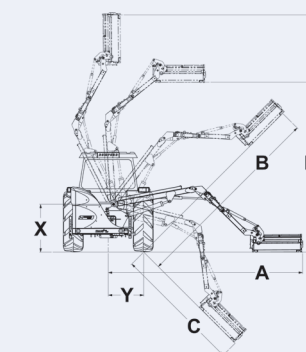

Forward Reach Falcon Evo 6.5m P VFA (21'4")	
A	6.61m / 21'8"
F	5.93m / 19'5"
G	6.4m / 21'
H	1.82m / 6'
J	0.9m / 2'11"

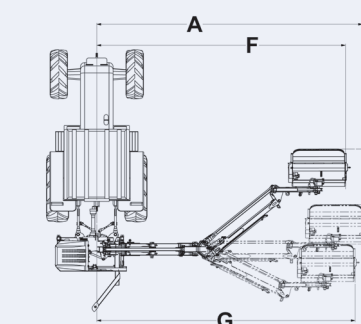

Falcon Evo Telescopic VFA

The Falcon Evo Telescopic VFA (Variable Forward Arm) is perfect for contractors and municipal environments, where the added benefits of a forward arm is required to improve visibility.

The Falcon Evo Telescopic VFA provides an unrivalled 2.1m total travel including 1.8m forward reach, resulting in an optimum mid-mounted cutting head position.

Key Features

- 6.5m reach
- Over 2m traverse on variable forward arm
- Axle bracket mounted only
- 125 l/min independent system



Want to know more about the Falcon Evo T-VFA range?

Scan the QR code with a smart phone or tablet to instantly view the page.



Telescopic second boom

To give greater reach in those harder to reach areas, all controlled from the in cab controls.

Close in ground cutting

Variable arm technology allows forward and rearward reach, enabling cutting in behind the tractor wheel.

Close in cutting capabilities

To allow cutting in tight spaces and narrow lanes.

Product Specification

● Standard ○ Optional — Not Available

Falcon Evo Telescopic VFA	T-VFA 6.5m (21'4")
Tractor requirements	
Minimum horse power	120hp
Minimum weight	5500kg / 12125lbs
Base unit mounting options	
Front mount	—
Mid-mount	—
Rear mount	●
Three point linkage (Cat 11)	—
Axle bracket	●
Overall machine parameters	
Machine weight with head and oil	2270kg / 5005lbs
Capacity of oil tank	250L / 66USG
Weight of machine with oil but without head	1980kg / 4365lbs
Controls	
Cable Control (CC)	●
Low pressure hydraulics (LPH)	—
Electronic proportional control (EPP)	○
Intelligent control system (ICS)	○
Cable rotor reverse	○
Electronic rotor reverse	○
Hydraulic system	
System capability	74hp
Pump flow rate	125L / 33USG
Pump type (Gear/Piston/Helical)	Gear
Pump arrangement (Twin/In-line)	Twin
Independent hydraulics	●
Oil cooler	●

Falcon Evo Telescopic VFA	T-VFA 6.5m (21'4")
Arm features and main frame	
Forward arm	2112mm / 6'11"
Telescopic arm	●
Telescopic arm stroke	900mm / 2'11"
Power slew	●
Power slew angle	94°
Gravity breakout protection	—
Hydraulic breakout protection	●
Arm float - manual operation	●
Arm float - electronic operation	○
Head float - manual operation	●
Head float - electronic operation	○
Left hand cutting	○
Right hand cutting	○
Left and right hand cutting	—
Arm attachments available	
Variable track bracket (VTB)	—
Sheartrim cutter bar	○
Pro-Saw	○
Ditch cleaner	○
Rotary head	○
Accessories	
Road Lights	●
Debris Blower	○
Cab Guard Kit	●
Cutting heads (For Flail compatibility see page 97)	
1.2m Pro-Cut - 115/150mm roller	●
1.5m Pro-Cut - 115/150mm roller	○
1.2m Pro-Cut ISMP - 115/150mm roller	○
2m HD head	○



Telescopic reach

The VFA allows total flexibility of position during arms operation.

Working Reach

Head used for calcs: 1.2m Pro-Cut

Side Reach Falcon Evo 6.5m T-VFA (21'4")	
A	6.5m / 21'4"
B	6.83m / 22'5"
C	4.61m / 15'2"
D	6.03m / 18'9"
E	7.66m / 25'2"
X	1.6m / 5'3"
Y	1.00m / 3'4"

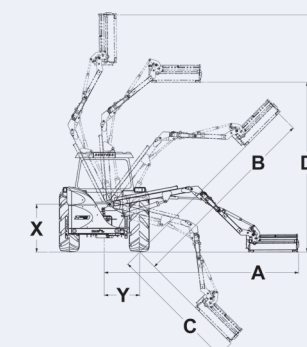

Forward Reach Falcon Evo 6.5m T-VFA (21'4")	
A	6.61m / 21'8"
F	5.93m / 19'5"
G	6.4m / 21'
H	1.82m / 6'
J	0.9m / 2'11"

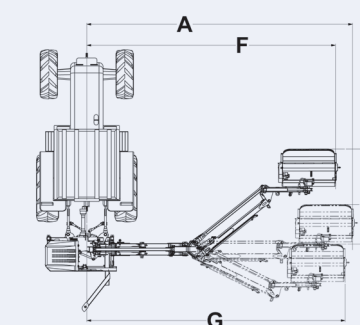

Front Mount Range

The Bomford front mount range is designed with local authorities in mind where front mounted operations are required.

There are numerous fitting options on this machine, for tractors, trucks and loading shovels.

Key Features

- 4.9m, 5.4m or 5.8m reach options
- Front mounted
- Low profile design for good forward visibility
- 125 l/min fully independent hydraulic system
- Left and right hand side cutting
- DIN3 plate mounting option
- Tractor front linkage option



Want to know more about the Front Mount range?

Scan the QR code with a smart phone or tablet to instantly view the page.



Fitting kits for trucks
Shown fitted to Unimog U500.



Fitting kits for tractor front linkages
Options for 1000/540 RPM.



Loading shovel fitting kits
Various makes and models available.

Product Specification

● Standard ○ Optional — Not Available

Front Mount Range	B49FM (16'4")	B54FM (17'9")	B58FM T (19')
Tractor requirements			
Minimum horse power	70hp	80hp	90hp
Minimum weight	4000kg 8819lbs	4250kg 9370lbs	4500kg 9921lbs
Base unit mounting options			
Front mount	●	●	●
Mid-mount	—	—	—
Rear mount	—	—	—
Three point linkage (Cat 11)	—	—	—
Axle bracket	—	—	—
Overall machine parameters			
Machine weight with head and oil	1400kg 3086lbs	1460kg 3219lbs	1540kg 3395lbs
Capacity of oil tank	227L 60USG	227L 60USG	227L 60USG
Weight of machine with oil but without head	1100kg 2425lbs	1160kg 2557bs	1240kg 2734lbs
Controls			
Cable Control (CC)	—	—	—
Low pressure hydraulics (LPH)	—	—	—
Electronic proportional control (EPP)	●	●	●
Intelligent control system (ICS)	○	○	○
Cable rotor reverse	—	—	—
Electronic rotor reverse	○	○	○
Hydraulic system			
System capability	74hp	74hp	74hp
Pump flow rate	125L 33USG	125L 33USG	125L 33USG
Pump type (Gear/Piston/Helical)	Gear	Gear	Gear
Pump arrangement (Twin/In-line)	Twin	Twin	Twin
Independent hydraulics	●	●	●
Oil cooler	●	●	●

Front Mount Range	B49FM (16'4")	B54FM (17'9")	B58FM T (19')
Arm features and main frame			
Forward arm	—	—	—
Forward arm reach (Fixed / Variable)	—	—	—
Telescopic arm	—	—	●
Telescopic arm stroke	—	—	900mm 3'
Power slew	●	●	●
Power slew angle	94°	94°	94°
Gravity breakout protection	—	—	—
Hydraulic breakout protection	●	●	●
Arm float - manual operation	○	○	○
Arm float - electronic operation	○	○	○
Head float - manual operation	○	○	○
Head float - electronic operation	○	○	○
Left hand cutting	○	○	○
Right hand cutting	○	○	○
Left and right hand cutting	●	●	●
Arm attachments available			
Variable track bracket (VTB)	—	—	—
Sheartrim cutter bar	○	○	○
Pro-Saw	○	○	○
Ditch cleaner	—	—	—
Rotary head	—	—	—
Accessories			
Road Lights	—	—	—
Debris Blower	—	—	—
Cab Guard Kit	●	●	●
Cutting heads (For Flail compatibility see page 97)			
1.2m Pro-Cut - 115/150mm roller	●	●	●
1.5m Pro-Cut - 115/150mm roller	○	○	○
1.2m Pro-Cut ISMP - 115/150mm roller	○	○	○



Telescopic second arm
On the B58FM T model.

Working Reach

Head used for calcs: 1.2 Pro-Cut

	B49FM 4.9m (16'4")	B54FM 5.4m (17'9")	B58FM T 5.8m (19')
A	4.9m / 16'4"	5.4m / 17'9"	5.8m / 19'
B	4.9m / 16'4"	5.4m / 17'9"	5.8m / 19'
C	3.4m / 11'2"	3.5m / 11'6"	3.6m / 11'10"
D	4.2m / 13'10"	4.7m / 15'7"	5m / 16'5"
E	6.1m / 20'	6.51m / 21'4"	6.7m / 22'
X	1.5m / 4'11"	1.5m / 4'11"	1.5m / 4'11"
Y	1.0m / 3'4"	1.0m / 3'4"	1.0m / 3'4"

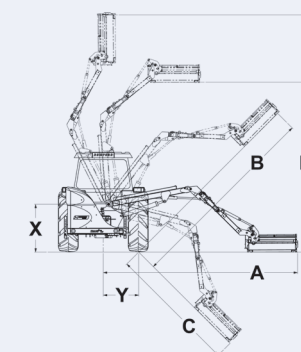

Buzzard Evo

The Buzzard Evo range has been specifically designed for the large scale contractor and agency.

With a large choice in specification, and fully proportional controls.

Key Features

- 7.25m or 8m reach
- 1.2m or 1.5m cutting heads
- Oil cooled as standard
- ICS fully proportional controls



Want to know more about the Buzzard Evo range?

Scan the QR code with a smart phone or tablet to instantly view the page.



Telescopic arm
Gives increased flexibility.



Powerful 74hp hydraulics
For continuous use. Twin pumps with separate oil tank.



Oil cooler
Standard on all models (cable controls as an option).

Product Specification

● Standard ○ Optional — Not Available

Buzzard Evo	7.25m T (23'9")	8.0m T (26'3")
Tractor requirements		
Minimum horse power	120hp	140hp
Minimum weight	5500kg 12125lbs	6000kg 13228lbs
Base unit mounting options		
Front mount	—	—
Mid-mount	—	—
Rear mount	●	●
Three point linkage (Cat 11)	—	—
Axle bracket	●	●
Overall machine parameters		
Machine weight with head and oil	2290kg 5049lbs	2490kg 5490lbs
Capacity of oil tank	250L 66USG	250L 66USG
Weight of machine with oil but without head	2000kg 4009lbs	2200kg 4850lbs
Controls		
Cable Control (CC)	○	○
Low pressure hydraulics (LPH)	○	○
Electronic proportional control (EPP)	○	○
Intelligent control system (ICS)	●	●
Cable rotor reverse	○	○
Electronic rotor reverse	○	○
Hydraulic system		
System capability	74hp	74hp
Pump flow rate	125L 33USG	125L 33USG
Pump type (Gear/Piston/Helical)	Gear	Gear
Pump arrangement (Twin/In-line)	Twin	Twin
Independent hydraulics	●	●
Oil cooler	●	●

Buzzard Evo	7.25m T (23'9")	8.0m T (26'3")
Arm features and main frame		
Forward arm	—	—
Telescopic arm	●	●
Telescopic arm stroke	1300mm 4'3"	1450mm 4'9"
Power slew	●	●
Power slew angle	94°	94°
Gravity breakout protection	—	—
Hydraulic breakout protection	●	●
Arm float - manual operation	—	—
Arm float - electronic operation	●	●
Head float - manual operation	○	○
Head float - electronic operation	●	●
Left hand cutting	○	○
Right hand cutting	○	○
Left and right hand cutting	—	—
Arm attachments available		
Variable track bracket (VTB)	○	○
Sheartrim cutter bar	○	○
Pro-Saw	○	○
Ditch cleaner	○	○
Rotary head	○	○
Accessories		
Road Lights	●	●
Debris Blower	○	○
Cab Guard Kit	●	●
Cutting heads (For Flail compatibility see page 97)		
1.2m Pro-Cut - 115/150mm roller	●	●
1.5m Pro-Cut - 115/150mm roller	○	○
1.2m Pro-Cut ISMP - 115/150mm roller	○	○
2m HD head	○	○



Fully enclosed hydraulics
Keeping components protected from the elements.

Working Reach

Head used for calcs: 1.2 Pro-Cut

	Buzzard Evo 7.25m T (23'9")	Buzzard Evo 8.0m T (26'3")
A	7.3m / 23'11"	7.94m / 26'1"
B	7.64m / 25'1"	8.07m / 26'6"
C	5.25m / 17'7"	5.91m / 19'5"
D	6.25m / 20'6"	6.86m / 22'6"
E	8.71m / 28'7"	8.87m / 29'1"
X	1.35m / 4'7"	1.35m / 4'7"
Y	1.00m / 3'4"	1.00m / 3'4"

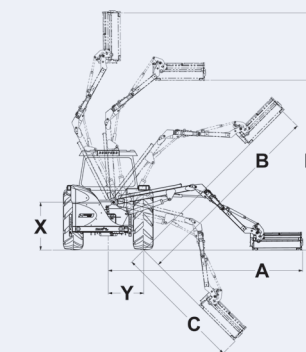

Buzzard Evo Forward

The Buzzard Evo forward range has been specifically designed for the large scale contractor and agency.

With the added advantage of forward reach, give improved visibility for the operator along with a large choice in specification, and fully proportional controls.

Key Features

- 7.25m or 8m reach
- 1.2m or 1.5m cutting heads
- Oil cooled as standard
- ICS fully proportional controls



Want to know more about the Buzzard Evo Fwd range?

Scan the QR code with a smart phone or tablet to instantly view the page.



Impressive reach

3 arm design gives versatile reach characteristics for flexibility around obstacles.

Transport position

Folding 3rd arm allows compact transport position.

Powerful 74hp hydraulics

For continuous use. Twin pumps with separate oil tank.

Product Specification

● Standard ○ Optional — Not Available

Buzzard Evo FWD	7.25m T (23'9")	8.0m T (26'3")
Tractor requirements		
Minimum horse power	120hp	140hp
Minimum weight	5500kg 12125lbs	6000kg 13228lbs
Base unit mounting options		
Front mount	—	—
Mid-mount	—	—
Rear mount	●	●
Three point linkage (Cat 11)	—	—
Axle bracket	●	●
Overall machine parameters		
Machine weight with head and oil	2290kg 5049lbs	2490kg 5490lbs
Capacity of oil tank	250L 66USG	250L 66USG
Weight of machine with oil but without head	2000kg 4409lbs	2200kg 4850lbs
Controls		
Cable Control (CC)	○	○
Low pressure hydraulics (LPH)	○	○
Electronic proportional control (EPP)	○	○
Intelligent control system (ICS)	●	●
Cable rotor reverse	—	—
Electronic rotor reverse	●	●
Hydraulic system		
System capability	74hp	74hp
Pump flow rate	125L 33USG	125L 33USG
Pump type (Gear/Piston/Helical)	Gear	Gear
Pump arrangement (Twin/In-line)	Twin	Twin
Independent hydraulics	●	●
Oil cooler	●	●

Buzzard Evo FWD	7.25m T (23'9")	8.0m T (26'3")
Arm features and main frame		
Forward arm	1200mm 3'11"	1200mm 3'11"
Telescopic arm	●	●
Telescopic arm stroke	—	—
Power slew	●	●
Power slew angle	94°	94°
Gravity breakout protection	—	—
Hydraulic breakout protection	●	●
Arm float - manual operation	—	—
Arm float - electronic operation	●	●
Head float - manual operation	○	○
Head float - electronic operation	●	●
Left hand cutting	○	○
Right hand cutting	○	○
Left and right hand cutting	—	—
Arm attachments available		
Variable track bracket (VTB)	○	○
Sheartrim cutter bar	○	○
Pro-Saw	○	○
Ditch cleaner	○	○
Rotary head	○	○
Accessories		
Road Lights	●	●
Debris Blower	○	○
Cab Guard Kit	●	●
Cutting heads (For Flail compatibility see page 97)		
1.2m Pro-Cut - 115/150mm roller	●	●
1.5m Pro-Cut - 115/150mm roller	○	○
1.2m Pro-Cut ISMP - 115/150mm roller	○	○



Forward reach position

Enables mid-mounted head position with simplicity of rear mounted arm.

Working Reach

Head used for calcs: 1.2 Pro-Cut

	Buzzard Evo FWD 7.25m T (23'9")	Buzzard Evo FWD 8.0m T (26'3")
A	7.19m / 23'7"	7.94m / 26'1"
B	7.27m / 23'10"	8.13m / 26'8"
C	5.47m / 17'11"	6.31m / 20'8"
D	6.8m / 22'4"	7.4m / 24'3"
E	8.52m / 27'11"	9.24m / 30'4"
X	1.35m / 4'7"	1.35m / 4'7"
Y	1.00m / 3'4"	1.00m / 3'4"

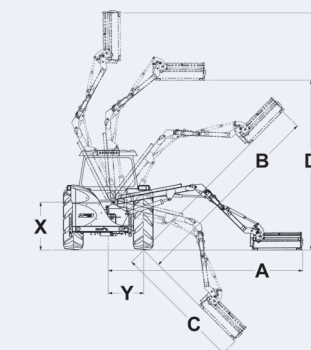

Buzzard Evo Telescopic VFA

The Buzzard Evo Telescopic VFA (Variable Forward Arm) is perfect for contractors and municipal environments, where the added benefits of a forward arm is required to improve visibility.

This latest flagship model in the VFA range provides an unrivalled 3.2m total travel including 2.1m forward reach, resulting in an optimum mid-mounted cutting head position.

Key Features

- 8.0m reach
- Over 3.2m traverse on variable forward arm
- Axle bracket mounted only
- 125 l/min independent system



Want to know more about the Buzzard Evo T-VFA range?

Scan the QR code with a smart phone or tablet to instantly view the page.



Telescopic second boom

To give greater reach in those harder to reach areas, all controlled from the in cab controls.

Close in ground cutting

Variable arm technology allows forward and rearward reach, enabling cutting in behind the tractor wheel.

Close in cutting capabilities

To allow cutting in tight spaces and narrow lanes.

Product Specification

● Standard ○ Optional — Not Available

Buzzard Evo Telescopic VFA	T-VFA 8.0m (26'3")
Tractor requirements	
Minimum horse power	120hp
Minimum weight	6000kg / 13228lbs
Base unit mounting options	
Front mount	—
Mid-mount	—
Rear mount	●
Three point linkage (Cat 11)	—
Axle bracket	●
Overall machine parameters	
Machine weight with head and oil	2270kg / 5005lbs
Capacity of oil tank	250L / 66USG
Weight of machine with oil but without head	1980kg / 4365lbs
Controls	
Cable Control (CC)	—
Low pressure hydraulics (LPH)	—
Electronic proportional control (EPP)	○
Intelligent control system (ICS)	●
Cable rotor reverse	—
Electronic rotor reverse	●
Hydraulic system	
System capability	74hp
Pump flow rate	125L / 33USG
Pump type (Gear/Piston/Helical)	Gear
Pump arrangement (Twin/In-line)	Twin
Independent hydraulics	●
Oil cooler	●

Buzzard Evo Telescopic VFA	T-VFA 8.0m (26'3")
Arm features and main frame	
Forward arm	2112mm / 6'11"
Telescopic arm	●
Telescopic arm stroke	900mm / 2'11"
Power slew	●
Power slew angle	94°
Gravity breakout protection	—
Hydraulic breakout protection	●
Arm float - manual operation	—
Arm float - electronic operation	●
Head float - manual operation	—
Head float - electronic operation	●
Left hand cutting	○
Right hand cutting	○
Left and right hand cutting	—
Arm attachments available	
Variable track bracket (VTB)	—
Sheartrim cutter bar	○
Pro-Saw	○
Ditch cleaner	○
Rotary head	○
Accessories	
Road Lights	●
Debris Blower	○
Cab Guard Kit	●
Cutting heads (For Flail compatibility see page 97)	
1.2m Pro-Cut - 115/150mm roller	●
1.5m Pro-Cut - 115/150mm roller	○
1.2m Pro-Cut ISMP - 115/150mm roller	○
2m HD head	○



Telescopic Reach

The VFA allows total flexibility of position during arms operation.

Working Reach

Head used for calcs: 1.2m Pro-Cut

Side Reach Buzzard Evo 8.0m T-VFA (26'3")	
A	8.0m / 26'3"
B	7.5m / 24'7"
C	6.0m / 19'8"
D	7.41m / 24'4"
E	8.62m / 28'3"
X	1.6m / 5'3"
Y	1.00m / 3'3"

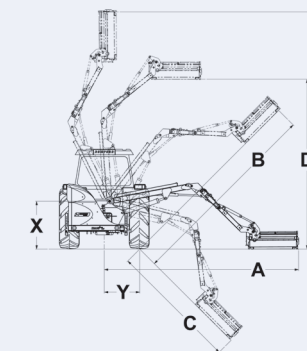

Forward Reach Buzzard Evo 8.0m T-VFA (26'3")	
A	8.0m / 26'3"
F	7.59m / 24'11"
G	7.76m / 25'5"
H	2.12m / 6'11"
J	0.9m / 2'11"

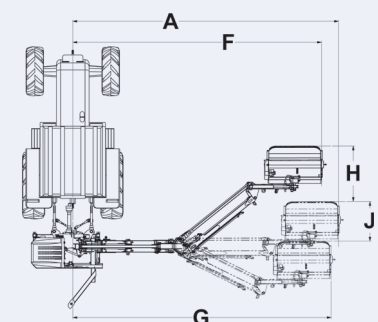

B71M B80M

A professional range of machines designed for smaller, lightweight tractors. Requiring only a mass of 4900kg for the tractor, this range of arm mowers really gives the contractor true flexibility.

The 3 arm arrangement gives a versatile reach characteristic, allowing cutting over obstacles such as fences and guard rails.

Key Features

- 7.1m or 8m reach
- 1.2m or 1.5m cutting heads
- Oil cooled as standard
- ICS fully proportional controls



Want to know more about the B71M & B80M range?

Scan the QR code with a smart phone or tablet to instantly view the page.



Heavy duty twin ram slew system

Includes hydraulic breakout to protect machine operator.



Forward reach position

Enables mid-mounted head position with simplicity of rear mounted arm.



Transport position

Folding 3rd arm allows compact transport position.

Product Specification

● Standard ○ Optional — Not Available

B71M & B80M	7.1m (23' 7")	8.0m (26' 3")
Tractor requirements		
Minimum horse power	120hp	140hp
Minimum weight	6000kg 13228lbs	6500kg 14330lbs
Base unit mounting options		
Front mount	—	—
Mid-mount	—	—
Rear mount	●	●
Three point linkage (Cat 11)	—	—
Axle bracket	●	●
Overall machine parameters		
Machine weight with head and oil	2290kg 5049lbs	2490kg 5490lbs
Capacity of oil tank	250L 66USG	250L 66USG
Weight of machine with oil but without head	2000kg 4409lbs	2200kg 4850lbs
Controls		
Cable Control (CC)	○	○
Low pressure hydraulics (LPH)	—	—
Electronic proportional control (EPP)	○	○
Intelligent control system (ICS)	●	●
Cable rotor reverse	○	○
Electronic rotor reverse	○	○
Hydraulic system		
System capability	74hp	74hp
Pump flow rate	125L 33USG	125L 33USG
Pump type (Gear/Piston/Helical)	Gear	Gear
Pump arrangement (Twin/In-line)	Twin	Twin
Independent hydraulics	●	●
Oil cooler	●	●

B71M & B80M	7.1m (23' 7")	8.0m (26' 3")
Arm features and main frame		
Forward arm	●	●
Telescopic arm	—	—
Telescopic arm stroke	—	—
Power slew	●	●
Power slew angle	110°	110°
Gravity breakout protection	—	—
Hydraulic breakout protection	●	●
Arm float - manual operation	○	○
Arm float - electronic operation	●	●
Head float - manual operation	○	○
Head float - electronic operation	●	●
Left hand cutting	○	○
Right hand cutting	○	○
Left and right hand cutting	—	—
Arm attachments available		
Variable track bracket (VTB)	○	○
Sheartrim cutter bar	○	○
Pro-Saw	○	○
Ditch cleaner	○	○
Rotary head	○	○
Accessories		
Road Lights	—	—
Debris Blower	—	—
Cab Guard Kit	●	●
Cutting heads (For Flail compatibility see page 97)		
1.2m Pro-Cut - 115/150mm roller	●	●
1.5m Pro-Cut - 115/150mm roller	○	○
1.2m Pro-Cut ISMP - 115/150mm roller	○	○



Reach great heights

With forward positioning and two reach options of 7.1m and 8.0m.

Working Reach

Head used for calcs: 1.2 Pro-Cut

	B71M 7.1M (23' 7")	B80M 8.0M (26' 3")
A	7.1m / 23' 7"	8.0m / 26' 3"
B	6.95m / 23'	7.85m / 25' 9"
C	5.27m / 17' 3"	6.17m / 20' 3"
D	4.75m / 15' 5"	5.65m / 18' 6"
E	8.26m / 26' 3"	8.9m / 29' 2"
X	1.35m / 4' 7"	1.35m / 4' 7"
Y	1.00m / 3' 4"	1.00m / 3' 4"

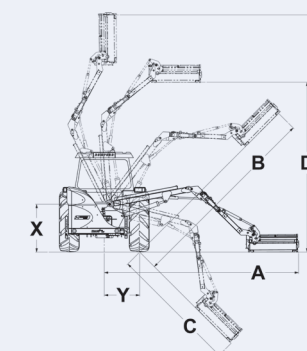

B81.81

A professional range of machines designed for smaller, lightweight tractors. Requiring only a mass of 4900kg for the tractor, this range of arm mowers really gives the contractor true flexibility.

Key Features

- 8.1m reach
- 1.2m or 1.5m cutting heads
- Oil cooled as standard
- ICS fully proportional controls



Want to know more about the B81.81 range?

Scan the QR code with a smart phone or tablet to instantly view the page.



Heavy duty twin ram slew system
Includes hydraulic breakout to protect machine operator.



Telescopic arm
Gives increased flexibility.



ICS Controls
Fingertip control with adjustable speed settings.

Product Specification

● Standard ○ Optional — Not Available

B81.81	8.1m T (26'7")
Tractor requirements	
Minimum horse power	140hp
Minimum weight	6500kg 14330lbs
Base unit mounting options	
Front mount	○
Mid-mount	—
Rear mount	●
Three point linkage (Cat 11)	—
Axle bracket	●
Overall machine parameters	
Machine weight with head and oil	2490kg 5490lbs
Capacity of oil tank	250L 66USG
Weight of machine with oil but without head	1955kg 4310lbs
Controls	
Cable Control (CC)	—
Low pressure hydraulics (LPH)	—
Electronic proportional control (EPP)	○
Intelligent control system (ICS)	●
Cable rotor reverse	—
Electronic rotor reverse	○
Hydraulic system	
System capability	74hp
Pump flow rate	125L 33USG
Pump type (Gear/Piston/Helical)	Gear
Pump arrangement (Twin/In-line)	Twin
Independent hydraulics	●
Oil cooler	●

B81.81	8.1m T (26'7")
Arm features and main frame	
Forward arm	—
Telescopic arm	●
Telescopic arm stroke	1450mm 4'9"
Power slew	●
Power slew angle	180°
Gravity breakout protection	—
Hydraulic breakout protection	●
Arm float - manual operation	—
Arm float - electronic operation	●
Head float - manual operation	—
Head float - electronic operation	●
Left hand cutting	○
Right hand cutting	○
Left and right hand cutting	●
Arm attachments available	
Variable track bracket (VTB)	○
Sheartrim cutter bar	○
Pro-Saw	○
Ditch cleaner	○
Rotary head	○
Accessories	
Road Lights	—
Debris Blower	—
Cab Guard Kit	●
Cutting heads (For Flail compatibility see page 97)	
1.2m Pro-Cut - 115/150mm roller	●
1.5m Pro-Cut - 115/150mm roller	○
1.2m Pro-Cut ISMP - 115/150mm roller	○
2m HD head	○



Transport cradle
For fast road transit.

Working Reach

Head used for calcs: 1.2 Pro-Cut

	B81.81 8.1m T (26'7")
A	8.08m / 26'6"
B	7.93m / 26'
C	6.27m / 20'7"
D	6.52m / 21'5"
E	8.92m / 29'3"
X	1.3m / 4'1"
Y	1.0m / 3'3"

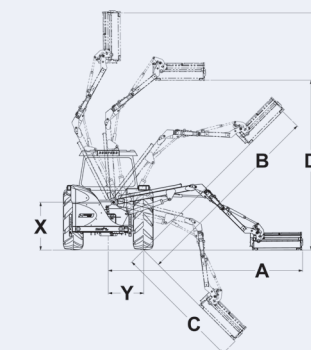

Eagle

The Eagle flail mower features a telescopic outer arm, giving it a maximum reach of 8.0 metres and the whole arm is mounted on a kingpost so that it can be slewed through 180 degrees for double sided, left or right-hand cutting.

The Eagle can be specified with either a gear or a piston system, and features wraparound steel hoses on the first arm and kingpost for durability and improved hose routing, along with weight saving.

Key Features

- 8m reach
- Left and right handed cutting
- 137 l/min independent hydraulic system
- 1.2m, 1.5m or 2m cutting head



Want to know more about the Eagle range?

Scan the QR code with a smart phone or tablet to instantly view the page.



Steel hoses

Improves hose routing and aids cooling.

Heavy duty twin ram slew system

Includes hydraulic breakout to protect machine operator.

Worm drive slew

New turntable design allows precise control of cutting head.

Product Specification

● Standard ○ Optional — Not Available

Eagle	8.0m T (26'4")
Tractor requirements	
Minimum horse power	160hp
Minimum weight	7000kg 15432lbs
Base unit mounting options	
Front mount	—
Mid-mount	—
Rear mount	●
Three point linkage (Cat 11)	—
Axle bracket	●
Overall machine parameters	
Machine weight with head and oil	2590kg 5710lbs
Capacity of oil tank	250L 66USG
Weight of machine with oil but without head	2230kg 4916lbs
Controls	
Cable Control (CC)	—
Low pressure hydraulics (LPH)	—
Electronic proportional control (EPP)	—
Intelligent control system (ICS)	●
Cable rotor reverse	—
Electronic rotor reverse	●
Hydraulic system	
System capability	85hp
Pump flow rate	137L 36USG
Pump type (Gear/Piston/Helical)	Gear
Pump arrangement (Twin/In-line)	Twin
Independent hydraulics	●
Oil cooler	●

Eagle	8.0m T (26'4")
Arm features and main frame	
Forward arm	—
Forward arm reach	—
Telescopic arm	●
Telescopic arm stroke	1300mm 4'3"
Power slew	●
Power slew angle	180°
Gravity breakout protection	—
Hydraulic breakout protection	●
Arm float - manual operation	—
Arm float - electronic operation	●
Head float - manual operation	—
Head float - electronic operation	●
Left hand cutting	○
Right hand cutting	○
Left and right hand cutting	●
Arm attachments available	
Variable track bracket (VTB)	—
Sheartrim cutter bar	○
Pro-Saw	○
Ditch cleaner	○
Rotary head	○
Accessories	
Road Lights	●
Debris Blower	—
Cab Guard Kit	●
Cutting heads (For Flail compatibility see page 97)	
1.2m Pro-Cut - 115/150mm roller	●
1.5m Pro-Cut - 115/150mm roller	○
1.2m Pro-Cut ISMP - 115/150mm roller	○
2m HD head	○



Improved main cutting circuit oil cooler

For better temperature control.

Working Reach

Head used for calcs: 1.2 Pro-Cut

Eagle 8.0M T (26'4")	
A	8.0m / 26'3"
B	7.8m / 25'7"
C	6.2m / 20'4"
D	7.0m / 23'
E	8.8m / 28'11"
X	1.2m / 3'11"
Y	1.2m / 3'11"

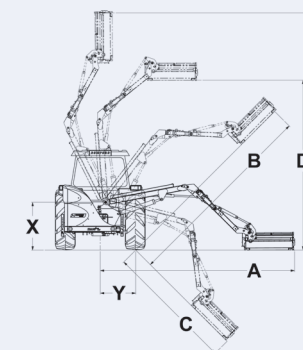

LANDSCAPE

Flail Mowers & Toppers

Bomford Turner offer a range of flail mowers and rotary toppers from simple grounds-care machines to agricultural-industrial mowers for municipal and airport landscape maintenance.

These machines are built with straightforward objectives: quality, function, value and robust design. The simple operation of the products in this range also ensures customer satisfaction every time.



Want to know more about our
Flail Mowers & Toppers range?

Scan the QR code with a smart phone or
tablet to instantly view the page.



Flail Mower & Toppers Range

Turbo Mower	60
Turbo Mower Offset	62
Raptor	63
Twin-Blade	64
Twin-Blade HD	66
Tri-Blade	67
Tri-Wing	68

Turbo Mower

The Turbo Mower Elite, Euro and Turbo Pro range offers operators a huge choice of cutting widths at very cost effective prices.

A well designed and constructed range, the Turbo Mower is built with durability and ease-of-use in mind – a low maintenance machine that is simple to operate.

Key Features

- Choice of cutting widths available
- Front mount options
- Hydraulic offset standard on all models
- Standard fitted roller and side skids
- Cat 11 three point linkage mounted
- Over run clutch protected



Want to know more about the Turbo Mower range?

Scan the QR code with a smart phone or tablet to instantly view the page.



Product Specification

● Standard ○ Optional — Not Available

Turbo Mower	ELITE 130 COMPACT	ELITE 150 COMPACT	ELITE 180 COMPACT	ELITE 200	ELITE 220	ELITE 250	ELITE 280
Working Width	1.3m / 4'3"	1.5m / 4'9"	1.8m / 5'9"	2.0m / 6'6"	2.2m / 7'2"	2.5m / 8'2"	2.8m / 9'2"
Overall Width	1.45m / 4'9"	1.65m / 5'5"	1.985m / 6'5"	2.2m / 7'2"	2.4m / 13'1"	2.7m / 8'9"	3.02m / 9'9"
Weight	250kg / 551lbs	290kg / 639lbs	390kg / 860lbs	655kgs / 1444lbs	705kg / 1554lbs	790kg / 1742lbs	1080kg / 2381lbs
Hydraulic Offset	●	●	●	●	●	●	●
Hydraulic Offset	400mm / 5 3/4"	400mm / 5 3/4"	400mm / 5 3/4"	400mm / 5 3/4"	400mm / 5 3/4"	400mm / 5 3/4"	400mm / 5 3/4"
Front Protection	Steel Flap	Steel Flap	Steel Flap	Steel Flap	Steel Flap	Steel Flap	Chains
Rear Protection	Rubber Flap	Rubber Flap	Rubber Flap	Rubber Flap	Rubber Flap	Rubber Flap	Rubber Flap
Linkage	Cat 1	Cat 1	Cat 1 / 11	Cat 11	Cat 11	Cat 11	Cat 11
PTO speed (rpm)	540	540	540	540	540	540	1000
Number of Belts	2	2	3	4	4	4	5
Mulching Bars	—	—	●	●	●	●	●
Front mount	—	—	—	—	—	—	—
No. of Flails (Whale Tail)	15	18	24	22	22	24	29
Width of Flails (Whale Tail)	80mm / 3 1/8"	80mm / 3 1/8"	85mm / 3 3/8"	135mm / 5 3/16"	135mm / 5 3/16"	135mm / 5 3/16"	135mm / 5 3/16"
Opening Rear Hood	—	—	●	●	●	●	—
Power requirements (min)	25 hp	25 hp	45-60 hp	55-75 hp	65-90 hp	75-100 hp	35-40 hp
Cutting height	32-111mm 1 1/4" - 4 3/8"	32-111mm 1 1/4" - 4 3/8"	30-60mm 1 1/8" - 2 3/8"	30-60mm 1 3/16" - 2 3/8"	30-60mm 1 3/16" - 2 3/8"	30-60mm 1 3/16" - 2 3/8"	30-60mm 1 3/16" - 2 3/8"
Roller size	140mm / 5 1/2"	140mm / 5 1/2"	140mm / 5 1/2"	170mm / 6 11/16"	170mm / 6 11/16"	170mm / 6 11/16"	220mm / 8 11/16"

Turbo Mower	EURO 250	EURO 280	TURBO PRO 280	TURBO PRO 300
Working Width	2.5m / 8'2"	2.8m / 9'2"	2.8m / 9'2"	3.0m / 9'9"
Overall Width	2.7m / 8'9"	3.05m / 10'	3.05m / 10'	3.2m / 10'5"
Weight	1040kg / 2293lbs	1060kg / 2337lbs	1250kg / 2756lbs	1350kg / 2976lbs
Hydraulic Offset	●	●	●	●
Hydraulic Offset	500mm / 19 11/16"	500mm / 19 11/16"	500mm / 19 11/16"	500mm / 19 11/16"
Front Protection	Steel Flap	Steel Flap	Chains	Chains
Rear Protection	Rubber Flap	Rubber Flap	Rubber Flap	Rubber Flap
Linkage	Cat 11	Cat 11	Cat 11 / 111	Cat 11 / 111
PTO speed (rpm)	1000	1000	1000	1000
Number of Belts	6	6	6	6
Mulching Bars	●	●	●	●
Front mount	●	●	●	●
No. of Flails (Whale Tail)	32	32	32	34
Width of Flails (Whale Tail)	100mm / 3 9/16"	100mm / 3 9/16"	100mm / 3 9/16"	100mm / 3 9/16"
Opening Rear Hood	—	—	●	●
Power requirements (min)	45-60 hp	55-75 hp	65-90 hp	75-100 hp
Cutting height	45mm 1 3/4"	45mm 1 3/4"	45mm 1 3/4"	45mm 1 3/4"
Roller size	170mm / 6 11/16"	170mm / 6 11/16"	220mm / 8 11/16"	220mm / 8 11/16"

Wear skids

Simple greasing and replaceable skids.

Hydraulic side shift

Hydraulic offset function on all models.

Easy adjustment

Simple belt tensioning system with oil filled drive tube.

Flail type

Heavy duty whale tail type flail fitted as standard.

Turbo Mower Offset



The Turbo Mower Offset range offers operators a choice of cutting widths at cost effective prices.

A well designed and constructed range, the Turbo Mower Offset is built with durability and ease-of-use in mind – a low maintenance machine that is simple to operate.

Key Features

- 1.6m, 2.0m, 2.25m and 2.5m cutting widths
- Three point linkage mounting
- PTO overrun protection, safety breakaway and double-skin protection
- 155 degrees of head movement
- Vertical and horizontal hydraulic adjustment
- Fuel-efficient, high-performance double spiral rotor
- Cutting height of 30mm - 80mm
- Maximum cutting diameter of 50mm



Product Specification

● Standard ○ Optional — Not Available

Turbo Mower Offset	160	200	225HD	250HD
Working Width	1.6m / 5'3"	2.0m / 6'7"	2.25m / 7'4"	2.5m / 8'2"
Weight	610kg / 1345lbs	670kg / 1477lbs	925kg / 2039lbs	1210kg / 2668lbs
Front Protection	Steel Flap	Steel Flap	Steel Flap	Steel Flap
Rear Protection	Rubber Flap	Rubber Flap	Rubber Flap	Rubber Flap
Linkage	Cat 11	Cat 11	Cat 11	Cat 11 / 111
PTO Speed (rpm)	540	540	540	540
No of Belts	3	3	4	5
Front Mount	—	—	—	—
No of Flails (Whale Tail)	16	22	22	24
Width of Flails	110mm / 4 ¹ / ₁₆	110mm / 4 ¹ / ₁₆	110mm / 4 ¹ / ₁₆	135mm / 5 ¹ / ₁₆
Power Requirements (min)	50hp	60hp	90hp	95hp
Cutting Height	30-80mm 1 ¹ / ₁₆ " - 3 ¹ / ₁₆ "	30-80mm 1 ¹ / ₁₆ " - 3 ¹ / ₁₆ "	30-80mm 1 ¹ / ₁₆ " - 3 ¹ / ₁₆ "	40mm 1 ¹ / ₁₆ "
Roller Size	140mm / 5 ¹ / ₂ "	140mm / 5 ¹ / ₂ "	170mm / 6 ¹ / ₁₆ "	170mm / 6 ¹ / ₁₆ "



Want to know more about the Turbo Mower Offset range?

Scan the QR code with a smart phone or tablet to instantly view the page.

Raptor

The new Raptor verge mower is the ideal choice for users who have a dedicated shoulder mowing operation to perform.

The Raptor can be front mounted allowing the fitting of a Bomford arm mower on the rear giving a 3.5m cut, in one pass. The Raptor can effortlessly work around street furniture and varying ground levels.

Key Features

- Cutting widths of 1.2, 1.6 or 2.0m.
- Front or rear mounted options
- Banks cutting between 90° up and 50° down
- Cat 11 three point linkage



Product Specification

● Standard ○ Optional — Not Available

Raptor	1200	1600	2000
Reach	2.84m / 9'4"	3.24m / 10'7"	3.64m / 12"
Cutting Width	1.2m / 4'	1.6m / 5'3"	2m / 6'6"
Max Offset	750mm / 2'6"	750mm / 2'6"	750mm / 2'6"
No. of Flails	32	44	54
PTO Speed (rpm)	1000 / 540	1000 / 540	1000 / 540
Cowl Angle Movement	140° (+90° to -50°)	140° (+90° to -50°)	140° (+90° to -50°)
Power Requirement	40hp	45hp	70hp
Weight	620kg / 1367lbs	830kg / 1830lbs	900kg / 1984lbs
Front Mountable	○	○	○



Want to know more about the Raptor range?

Scan the QR code with a smart phone or tablet to instantly view the page.

Twin-Blade

The new, more robust Twin-Blade is a flexible, efficient, in-line topper or fully offset - perfect for paddocks and headlands.

The range extends from 1.25m and semi-offset to 2.8m, along with a fully offset 2.4m. The Twin-Blade also features cast-iron gearboxes and protected drivelines. Simple, adjustable skids on this machine are key to a smooth operation.

Key Features

- Shaft driven
- 1.25m, 1.45m, 1.85m, 2.4m, 2.4m offset and 2.8m cutting width
- Variable cutting height
- Shearbolt and overrun gear box protection
- Cat 1 or Cat 11 three point linkage
- A-Frame mounting option



Want to know more about the Twin Blade range?

Scan the QR code with a smart phone or tablet to instantly view the page.



Transport position
For fully offset 2400 (8') machine



Choice of models
Inline 1.25m to 1.85m model



Adjustable skids
Simple to adjust for smooth operation



Product Specification

Twin-Blade	TB125	TB145	TB185	TB240	TB280	TB240 Offset
Cutting Width	1210mm / 4'	1420mm / 4'8"	1725mm / 5'11"	2600mm / 8'6"	2800mm / 9'2"	2400mm / 7'10"
Overall Width (Transport)	1345mm / 4'5"	1545mm / 5'1"	1875mm / 7'6"	2850mm / 9'4"	3050mm / 10'	1850mm / 6'1"
Weight	220kg / 485lbs	265kg / 584lbs	540kg / 640lbs	425kg / 936lbs	525kg / 1157lbs	550kg / 1213lbs
Linkage Mounting	Cat 1	Cat 1	Cat 11	Cat 11	Cat 11	Cat 11
PTO Speed (rpm)	540	540	540	540	540	540
Number of Rotors	1	1	1	2	2	2
Number of Blades	2	2	3	4	4	4
Power Requirement (min)	25hp	25hp	45hp	50hp	60hp	45hp
PTO shaft protection	Shearbolt	Shearbolt	Slip clutch	Slip clutch	Slip clutch	Shearbolt
Cutting Height	10-90mm 3/8" - 3 3/8"	10-90mm 3/8" - 3 3/8"	10-90mm 3/8" - 3 3/8"	30-90mm 1 1/8" - 3 3/8"	30-90mm 1 1/8" - 3 3/8"	30-150mm 1 1/8" - 6"
Semi Offset	Inline	Inline	Inline	Inline	Inline	Fully offset



Inline 2.8m (9'2")
Ideal for paddock topping

Twin-Blade HD

The Twin-Blade HD is a rugged topper available in 8' or 9' cutting widths. The HD has the standard features of both adjustable depth skids, and the adjustable castor wheels to control cutting height.

The HD model is constructed with a 4mm Domex steel and a main input gearbox capable of 150HP, and fitted as standard with a durable slip clutch PTO shaft. There are a number of blade options available, from standard grass blades, dome anti scalp kit, and shredder blades.

Key Features

- Shaft driven
- 2.4m and 2.7m cutting width
- Adjustable depth skids and adjustable castor wheels
- Variable cutting height
- 4mm Domex steel construction
- Various blade options available
- Cat 11 three point linkage



Product Specification

Twin-Blade HD	2400	2700
Cutting Width	2.4m / 7'10"	2.7m / 8'10"
Transport Width	2.69m / 8'10"	2.98m / 9'9"
Power Requirements	80hp	110hp
Length	2.95m / 9'8"	2.95m / 9'8"
Cutting Height	50mm-175mm / 2"-7"	50mm-175mm / 2"-7"
PTO Speed	1000rpm	1000rpm
Number Of Rotors	2	2
Number Of Blade Carriers	2	2
Number Of Blades	4	4
Number Of Skids	2	2
Weight	856kg / 1887lbs	923kg / 2034lbs



Want to know more about the Twin-Blade HD range?

Scan the QR code with a smart phone or tablet to instantly view the page.

Tri-Blade

The Tri-Blade topper is of robust design and has three sets of newly designed, heavy duty timed blades for stripe free cutting.

With an adjustable cutting height of between 25mm (1") and 333mm (10") the Bomford Tri-Blade offers superb versatility.

Direct driven blades through 1000rpm independent gearboxes and rubber PTO shaft couplings protects against debris impact. Slip clutch protection on the PTO shaft ensures long life of the independent gearboxes.

Key Features

- 2.75m cutting width
- 3.0m transport width
- Variable cutting height
- Three sets of timed blades
- Slip clutch protection
- Front and rear heavy duty chain guards
- Cat 11 three point linkage
- 1000 rpm gearbox driven



Product Specification

Tri-Blade	3000
Cutting Width	2.75m / 9'
Transport Width	3.0m / 9'10"
Power Requirements	90hp
Length	3.54m / 11'4"
Cutting Height	25mm - 333mm / 1" - 10"
PTO Speed	1000rpm
Number Of Rotors	3
Number Of Blade Carriers	3
Number Of Blades	6
Number Of Skids	2
Weight	980kg / 2161lbs



Want to know more about the Tri-Blade range?

Scan the QR code with a smart phone or tablet to instantly view the page.

Tri-Wing

A flex mower specifically designed for large open spaces, with wide-angle constant velocity drive shafts and in-line slip clutch protection.

The clean lines of this robust design, reduces the build up cut debris from collecting and rotting the machine deck, maximising it's working life.

Fitted with six 200/60 - 14.5 10 ply tyres as standard, the Tri-Wing 4.6 and 6m can also be also supplied with an eight wheel option for reduced ground pressure. The hydro-suspension shock absorbing mechanism ensures a smooth ride and reduces stress within the mainframe.

Key Features

- 4.6m and 6m cutting widths
- Walking wheel kit option
- Nine heavy duty updraft blades
- Choice of 5 blade configurations
- Shredder option for maize
- Hydro-suspension system
- Hydraulic level lift system



Want to know more about the Tri-Wing range?

Scan the QR code with a smart phone or tablet to instantly view the page.



Road lights

High speed road lighting and licence plate brackets.



Axle options

Walking axle options for contour following operation.



Contoured decks

Allows quick cleaning of cut material from deck surface.

Product Specification

Tri-Wing	TW4600	TW6000
Cutting Width	4.60m / 15'	6.00m / 20'
Overall Width	4.75m / 15'7"	6.30m / 20'8"
Overall Length	4.9m / 16'4"	5.5m / 18'1"
Transport Width	2.5m / 8'2"	2.4m / 7'10"
Cutting Height	13mm - 393mm / 1/2" - 15"	13mm - 393mm / 1/2" - 15"
Horsepower (min)	80hp	100hp
Tip Speed	80 m/s	80 m/s
PTO Speed	1000	1000
Wing Flex (Degrees)	107° up - 21° down	109° up - 10° down
Weight (Approx)	2385kg / 5258lbs	2775kg / 6117lbs



Easy to transport

Simple single operation to fold and travel, with additional locking pins for road transit.



Wide coverage

4.6m and 6.0m models allow wide cutting passes to tackle large open areas quickly.

FORESTRY

Mulchers & Excavators

A range of robust, simple and effective forestry equipment. Our mulchers come with a choice of hammers and are available tractor mounted or excavator mounted.

The Bomford Turner range of robust and effective mulchers offers real versatility with 2 ranges, standard duty (SD) swinging hammer and heavy duty (HDX) with fixed hammers. Capable of clearing and mulching wood up to 200mm diameter (8") on the Buccaneer HDX models, large areas can be cut, mulched and cleared in a single operation.



Want to know more about our Forestry range?

Scan the QR code with a smart phone or tablet to instantly view the page.



Forestry Range

Buccaneer
Hurricane

72
74

Buccaneer

Suitable for use with tractors of between 110hp to 120hp and features a heavy duty gearbox. The robust build means that the smaller SD machine weighs 1,260kg while the wider HDX model comes in at 2,150kg.

The standard specification of the new Bomford Buccaneer HDX includes a front double-row chain guard, Cat 11/111 three-point linkage and heavy-duty replaceable skids. A front mounted version of the Buccaneer HDX is also available.

Key Features

- Fixed or swinging flail options
- 5 belt driven (8 on HDX model)
- 110-120hp tractor requirement options
- Rear pushbar standard on both models
- Replaceable skids
- 540rpm or 1,000rpm



Want to know more about the Buccaneer range?

Scan the QR code with a smart phone or tablet to instantly view the page.



Heavy duty drive

5 belt drive on SD models and 8 belts (dual drive) on HDX ranges.

Swinging hammer options

Ideal for use on green vegetation for shredding.

Protection

Double rows of heavy chains and adjustable skids.

Product Specification

● Standard ○ Optional — Not Available

Buccaneer	SD 220	HDX 220
Working Width	2.2m / 7'2"	2.2m / 7'2"
Overall Width	2.5m / 8'2"	2.76m / 9'
Weight	1260kg / 2778lbs	2150kg / 4740lbs
Front Protection	Chains	Chains
Rear Protection	Hydraulic Opening Hood	Hydraulic Opening Hood
Rear Protection	Mechanical Push Bar	Hydraulic Push Bar
Linkage	Cat 11 / 111	Cat 11 / 111
PTO Speed (rpm)	540	1000
No of Belts	5	8
Front Mount	○	—
Flail Type	Swinging Hammer	Fixed Hammer
No of Flails (Whale Tail)	40	36
Opening Rear Hood	●	●
Power Requirements (min)	110hp	120hp
Cutting Diameter	100mm / 3 ¹⁵ / ₁₆ "	200mm / 8"



Fixed hammers

Options available. Suitable for managing wooded areas and providing a chipped wood finish. Benefits are mulching the debris within the soil leaving the ground level.



Push bars

Rear push bars fitted as standard enable material to be pushed over and presented to the cutting rotor. Hydraulic rear hood for closing down rear opening for mulching.

Hurricane

A semi forestry mower fitted with chains or blades and suitable for all types of clearance applications.

A well designed and constructed range, the Hurricane is built with durability and ease-of-use in mind, fitted with high quality Grade 80 chains and adjustable skids.

The Grade 80 chain is a heat-treated steel chain with a high strength-to-weight ratio. Its strength makes it safe for overhead lifting and lifting slings. It is also excellent for recovery, safety, and towing chains.

Key Features

- 10mm top deck with reinforcement strengthening supports
- 540 RPM c/w slip clutch as standard
- Simple height adjustment
- Adjustable skid height from 50 – 100mm
- Heavy duty lifting chains
- 18 mm chain size
- Cat 11 linkage
- Heavy duty gearbox 140 hp



Want to know more about the Hurricane range?

Scan the QR code with a smart phone or tablet to instantly view the page.



3 Heavy duty cutting chains
3 Chains per rotor in Grade 80 steel to work in stony conditions.



Adjustable skid height
From 50 – 100mm.



Protection
Heavy duty chain guard protection.

Product Specification

Hurricane	Hurricane 165	Hurricane 185	Hurricane 210
Working Width	1.6m / 5'2"	1.725m / 5'7"	2.05m / 6'7"
Overall Width	1.75m / 5'7"	1.875m / 6'2"	2.15m / 7'1"
Weight	490kg / 1080lbs	540kg / 1190lbs	630kg / 1389lbs
Front Protection	Chains	Chains	Chains
Rear Protection	Chains	Chains	Chains
Linkage	Cat 11	Cat 11	Cat 11
PTO Speed (rpm)	540	540	540
No of Chains	3	3	3
Power Requirements (min)	45hp	45hp	45hp



Heavy duty topper

Suitable for cutting rough terrain and wooded areas.

REMOTE

Wirelessly Operated

Remote controlled flail mowers offer fast, effective and safe vegetation control on steep, remote and challenging terrains.

The wide variety of attachments available for this range - which include dozer blades, sweepers, loaders, snow blowers and rakes - offer an extremely versatile remote controlled solution.



Want to know more about our Remote range?

Scan the QR code with a smart phone or tablet to instantly view the page.



Remote Range

Flailbot Mini	78
Flailbot Compact T4F	80
Flailbot Original T4F	82
Flailbot Supreme T4F	84

Flailbot Mini

The smallest of the Flailbot range, but packed with all the innovative features of the larger models. Easy access to site, with a lower gross weight and smaller foot print.

With a punchy 25hp engine, whilst it appears to be small, the Flailbot Mini model is very capable. Cutting head size is 1000mm (32 3/4") and this makes this model perfect for small access sites, and to be transported on smaller vehicles between sites.

Key Features

- 2 cylinder Honda petrol engine
- 17 litre (4.5 USG) fuel capacity
- Closed circuit piston pump cutting circuit
- 40 degree working angle
- Hydrostatic transmission



Want to know more about the Flailbot Mini?

Scan the QR code with a smart phone or tablet to instantly view the page.



Sleek low design

Giving maximum accessibility to difficult areas whilst remaining well protected with full engine covers.



Integral rollbar

Standard on all Flailbot models, and offers the additional feature of lift points.

Flailbot Mini Weights & Dimensions

Engine Size / Capacity
25hp /
0.779 Litres / 47.54 in³

Flailbot with Oil & Fuel
570 kg / 1,256 lbs

1000 Flail Head
160 kg / 352 lbs

Features & Specification

Flailbot	Mini (25hp)
Operation	
Max Slope	40°
Transmission	Hydrostatic
Speed	0-6 km/h
Weight	570kg / 1,257lbs
Engine	
Brand / Make	Honda
Model	2 Cylinders, Petrol
Engine Size	0.779 Litres / 47.54 in ³
Power	18.6 kW / 25 Cv
Max Torque	54.5 Nm / 40 ft-lb @ 2500 rpm
Intake	Aspirated
Cooling	Air
Air Filter	Dry
Petrol Tank Capacity	17 Litres / 4.5 USG
Engine Oil Quantity	1.4 Litres / 0.4 USG
Electrical Circuit	
Operating Voltage	12 Vcc
Alternator	16 Amp
Battery	18 Ah

Flailbot	Mini (25hp)
Hydraulic System	
Displacement	Tandem piston pump with variable engine size and closed circuit
Displacement Capacity	64 Litres max @ 3200 rpm 17 USG max @ 3200 rpm
Displacement Pressure	250 Bar max
Services	Gear Pump
Services Capacity	13 Litres max @ 3200 rpm 3.4 USG max @ 3200 rpm
Services Pressure	150 Bar max
Tool	Closed Circuit Piston Pump
Tool Capacity	45 Litres max @ 3200 rpm 11.9 USG max @ 3200 rpm
Tool Pressure	180 Bar max
Oil Tank Capacity	22 Litres / 5.8 USG
Operating Oil Quantity	30 Litres / 8 USG
Controls	
Brand	IMET
Frequency	2.4 Ghz
Range Signal	100m / 328'
Battery	Rechargeable



Hydraulic front hood

Operational via controls with electronic interlock for safety dependent on rotor direction.

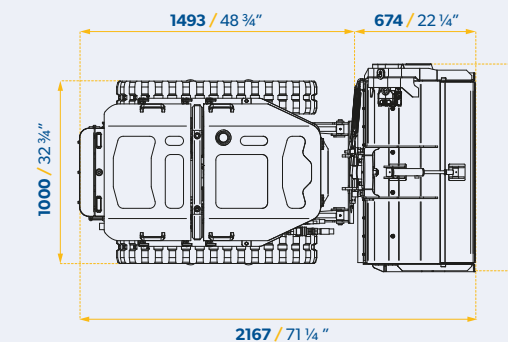
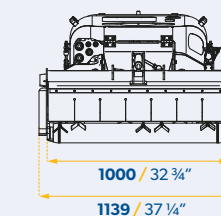
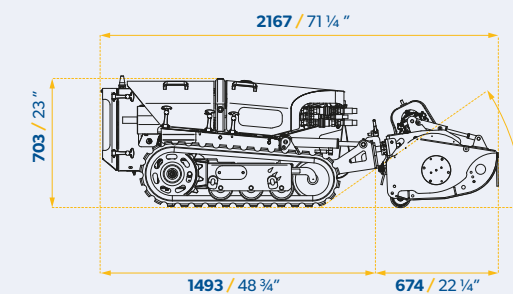

Flailbot Compact T4F

Flailbot Compact T4F carries all the same features as the Mini model, with the bigger Flailbot 50hp Perkins industrial powerplant.

The compact size, but powerful 50hp Perkins engine makes the compact model a contractors first choice. With the added feature of manual wind out track width as standard, and a number of attachments available.

Key Features

- Perkins 50hp industrial engine
- 1300mm (51") cutting head
- Manually wind out track frame
- Auto hydraulic track tension system
- Full engine covers as standard



Want to know more about the Flailbot Compact T4F?

Scan the QR code with a smart phone or tablet to instantly view the page.



Radiator cooler cover
Hinged cooler guard for easy access.



Easy access
Engine protection covers easily removed for fast and simple access for maintenance.

Flailbot Compact T4F Weights & Dimensions

Engine Size / Capacity
50hp /
1.6 Litres / 101.4 in³

Flailbot with Oil & Fuel
1110 kg / 2,425lbs

1300 Flail Head
210 kg / 462 lbs

Features & Specification

Flailbot	Compact T4F (50hp)
Operation	
Max Slope	55°
Transmission	Hydrostatic
Speed	0-7 km/h
Weight	1110kg / 2,425lbs
Engine	
Brand / Make	Perkins
Model	3 Cylinders, Diesel
Engine Size	1.662 Litres / 101.4 in ³
Power	36 kW / 49 Cv
Max Torque	166 Nm / 122 ft-lb @ 1800 rpm
Intake	Turbocharged
Cooling	Liquid
Air Filter	Dry
Diesel Tank Capacity	24 Litres / 6.3 USG
Engine Oil Quantity	6 Litres / 2 USG
Electrical Circuit	
Operating Voltage	12 Vcc
Alternator	85 Amp
Battery	44 Ah

Flailbot	Compact T4F (50hp)
Hydraulic System	
Displacement	Tandem piston pump with variable engine size and closed circuit
Displacement Capacity	104 Litres max @ 2750 rpm 27 USG max @ 2750 rpm
Displacement Pressure	320 Bar max
Services	Gear Pump
Services Capacity	15 Litres max @ 2750 rpm 4 USG max @ 2750 rpm
Services Pressure	200 Bar max
Tool	Closed Circuit Piston Pump
Tool Capacity	77 Litres max @ 2750 rpm 20 USG max @ 2750 rpm
Tool Pressure	320 Bar max
Oil Tank Capacity	25 Litres / 7 USG
Operating Oil Quantity	35 Litres / 9 USG
Controls	
Brand	Scanreco
Frequency	2.4 Ghz
Range Signal	150m / 492'
Battery	Rechargeable



Working range
All Flailbot models have an impressive working range of 150m (492').

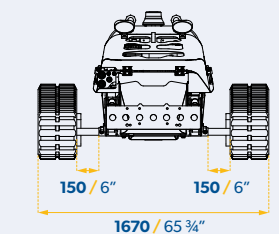
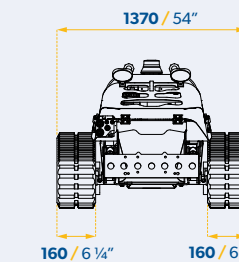
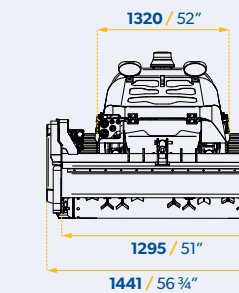
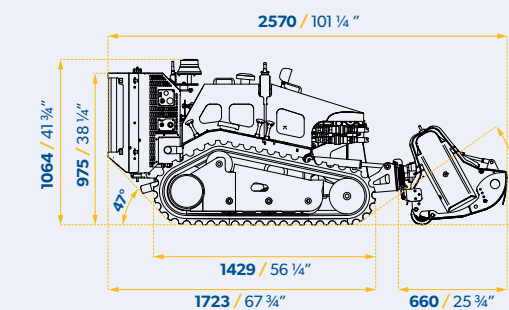

Flailbot Original T4F

Flailbot Original T4F continues to draw from the success of its predecessor, with the heritage of being the market leading diesel-powered slope mower.

The original Flailbot, now updated to 50hp, designed for challenging terrains with the powerful industrial Perkins diesel engine fitted as standard, providing the ultimate in power to weight performance in the remote controlled tracked tool carrier market.

Key Features

- 3 Cylinder 50hp T4F Perkins engine
- 29 litre (8 USG) fuel tank capacity
- Closed circuit tandem piston pump with variable displacement
- 150m (492') working range
- 55 degree max working angle



Want to know more about the Flailbot Original T4F?

Scan the QR code with a smart phone or tablet to instantly view the page.



Excellent grip characteristics

Individual tracks can be extended by up to 250mm (10").



Perkins engine accessibility

Removable steel engine panels for easy access.

Flailbot Original T4F Weights & Dimensions

Engine Size / Capacity

50hp /
1.6 Litres / 101.4 in³

Flailbot with Oil & Fuel
1400 kg / 3,086 lbs

1500 Flail Head
225 kg / 496 lbs

Features & Specification

Flailbot	Original T4F (50hp)
Operation	
Max Slope	55°
Transmission	Hydrostatic
Speed	0-7 km/h
Weight	1400kg / 3,086lbs
Engine	
Brand / Make	Perkins
Model	3 Cylinders, Diesel
Engine Size	1.662 Litres / 101.4 in ³
Power	36 kW / 49 Cv
Max Torque	166 Nm / 122 ft-lb @ 1800 rpm
Intake	Turbocharged
Cooling	Liquid
Air Filter	Dry
Diesel Tank Capacity	29 Litres / 8 USG
Engine Oil Quantity	7 Litres / 2 USG
Electrical Circuit	
Operating Voltage	12 Vcc
Alternator	85 Amp
Battery	44 Ah

Flailbot	Original T4F (50hp)
Hydraulic System	
Displacement	Tandem piston pump with variable engine size and closed circuit
Displacement Capacity	104 Litres max @ 2750 rpm 27 USG max @ 2750 rpm
Displacement Pressure	320 Bar max
Services	Gear Pump
Services Capacity	15 Litres max @ 2750 rpm 4 USG max @ 2750 rpm
Services Pressure	200 Bar max
Tool	Closed Circuit Piston Pump
Tool Capacity	77 Litres max @ 2750 rpm 20 USG max @ 2750 rpm
Tool Pressure	320 Bar max
Oil Tank Capacity	50 Litres / 13 USG
Operating Oil Quantity	60 Litres / 16 USG
Controls	
Brand	Scanreco
Frequency	2.4 Ghz
Range Signal	150m / 492'
Battery	Rechargeable



Precise control

The remote control, operating all Flailbot functions has a range of 150m (492').

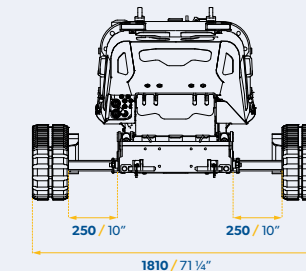
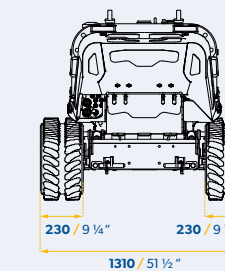
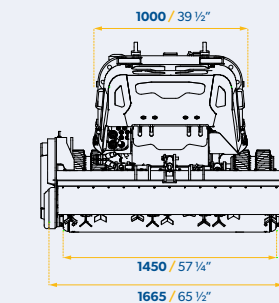
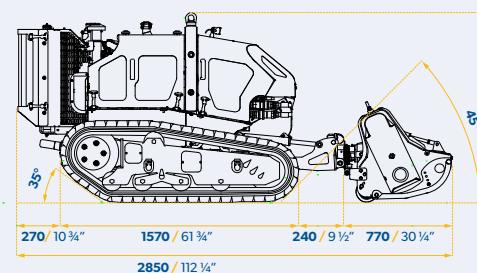

Flailbot Supreme T4F

The flagship model – enjoy ultimate horse power with the 75hp engine giving maximum power and control to the operators finger tips.

Fitted with a tier 4 Final Perkins engine, producing over 200 NM of torque making the Flailbot Supreme the most powerful model in the range. The Supreme is fitted as standard with hydraulic adjustable track width and auto track tension system.

Key Features

- 4 Cylinder 75hp T4F Perkins engine
- Tier 4 final engine emissions
- Hydraulically adjustable track frame
- 39 litre (10 USG) fuel tank capacity
- 150m (492') working range



Want to know more about the Flailbot Supreme T4F?

Scan the QR code with a smart phone or tablet to instantly view the page.



Clearing areas of dense vegetation
Cutting through heavy undergrowth to allow easy access.



Rear protection
Fitted with rear protection bar and towing anchor point.

Flailbot Supreme T4F Weights & Dimensions

Engine Size / Capacity
75hp /
2.2 Litres / 134.2 in³

Flailbot with Oil & Fuel
2200 kg / 4,850 lbs

1650 Flail Head
450 kg / 992 lbs

Features & Specification

Flailbot	Supreme T4F (75hp)
Operation	
Max Slope	55°
Transmission	Hydrostatic
Speed	0-7 km/h
Weight	2200kg / 4,850 lbs
Engine	
Brand / Make	Perkins, Tier 4 Final
Model	4 Cylinders, Diesel, Direct Injection
Engine Size	2.2 Litres / 134.2 in ³
Power	55 kW / 75 Cv
Max Torque	270 Nm / 199 ft-lb @ 1800 rpm
Intake	Turbocharged aftercooled
Cooling	Liquid
Air Filter	Dry
Diesel Tank Capacity	39 Litres / 10.3 USG
Engine Oil Quantity	10 Litres / 2.6 USG
Electrical Circuit	
Operating Voltage	12 Vcc
Alternator	85 Amp
Battery	70 Ah

Flailbot	Supreme T4F (75hp)
Hydraulic System	
Displacement	Tandem piston pump with variable engine size and closed circuit
Displacement Capacity	154 Litres max @ 2750 rpm 40 USG max @ 2750 rpm
Displacement Pressure	400 Bar max
Services	Gear Pump
Services Capacity	15 Litres max @ 2750 rpm 4 USG max @ 2750 rpm
Services Pressure	200 Bar max
Tool	Closed Circuit Piston Pump
Tool Capacity	93 Litres max @ 2500 rpm 24.6 USG max @ 2500 rpm
Tool Pressure	380 Bar max
Oil Tank Capacity	72 Litres / 19 USG
Operating Oil Quantity	82 Litres / 22 USG
Controls	
Brand	Scanreco
Frequency	2.4 Ghz
Range Signal	150m / 492'
Battery	Rechargeable



Shredding head
Fitted as standard with 1650mm (5'5") shredding head and pushbar.

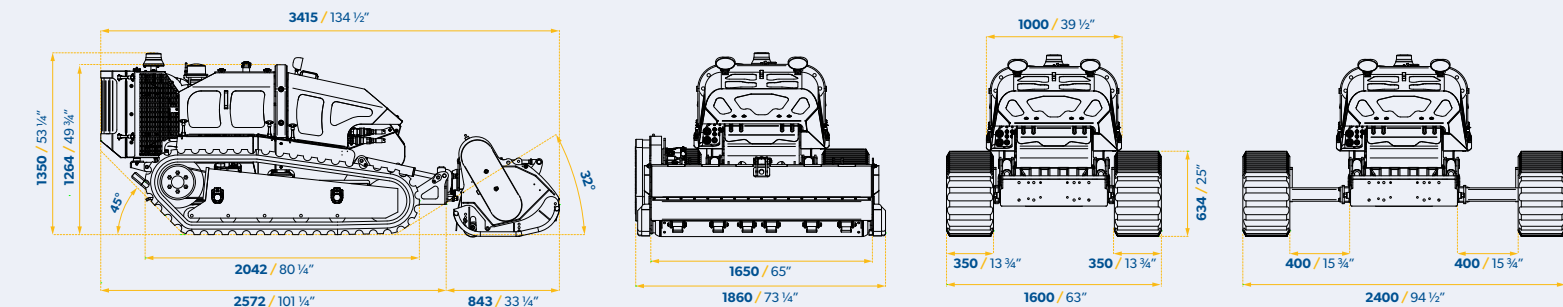

CULTIVATION

Agricultural Cultivators

A range of low cost surface cultivators, ranging from 2.0m to 5.0m working widths. 3 point linkage mounted and surface driven.

Bomford Turner have a history of producing quality simple cultivators. The goal has always remained the same; simple, low maintenance and cost effective. Our Dyna-Drive ground-driven cultivator meets each of these goals and is offered in a range of working widths.



Want to know more about our Cultivation range?

Scan the QR code with a smart phone or tablet to instantly view the page.



Cultivation Range

Dyna-Drive

88

Dyna-Drive

Simple and effective ground driven cultivator, for use on all types of soil at high speed.

Designed in conjunction with the NIAE, the Dyna-Drive enables successive cereal crops to be sown at reduced costs and in faster times than with traditional methods of cultivation.

Low running costs as a result of no PTO drive. This reduces power requirement so forward speed is not restricted, so large areas can be covered quickly. Average forward speed of 12 km/hr and then typically outputs of 3.13 ha/hr up to 6.0 ha/hr can be achieved dependent upon soil type.*

Key Features

- 1.6, 2.0, 2.6, 3.0, 4.0 or 5.0m widths
- 4.5 and 6.5m Flex options also available
- Maintenance free drive system
- Breaks up stubble, breaks down ploughing
- No PTO required
- Crumbler or Packer roller options
- Specialist vineyard option available

*Based on 5m working width



Want to know more about the Dyna-Drive range?

Scan the QR code with a smart phone or tablet to instantly view the page.



Product Specification

Dyna-Drive	1.6m	2.0m	2.6m	3.0m	4.0m	5.0m	Flex 4.5m	Flex 6.5m
Working Width	1.6m / 5'3"	2.0m / 6'7"	2.6m / 8'6"	3.0m / 9'10"	4.0m / 13'1"	5.0m / 16'5"	4.0m / 13'1"	6.0m / 19'8"
Transport Width	2.0m / 6'7"	2.4m / 7'11"	3.0m / 9'10"	3.4m / 11'2"	4.4m / 14'5"	5.4m / 17'8"	2.5m / 8'2"	2.5m / 8'2"
Tractor Power Required	37-52 kW 50-70 bhp	45-70 kW 60-90 bhp	60-90 kW 80-120 bhp	100 kW 90-130 bhp	140 kW 30-180 bhp	180 kW 160-240 bhp	195 kW 220-260 bhp	220 kW 250-300 bhp
Output Guide 7.5 mph (12kph)	2.0 ha/hr 4.94 ac/hr	2.42 ha/hr 6.05 ac/hr	3.13 ha/hr 7.82 ac/hr	3.60 ha/hr 9.00 ac/hr	4.80 ha/hr 12.00 ac/hr	6.00 ha/hr 16.00 ac/hr	4.80 ha/hr 12.00 ac/hr	7.20 ha/hr 20.00 ac/hr
Weight Including Crumbler	1050 kg 2315 lb	1040 kg 2293 lb	1320 kg 2911 lb	1480 kg 3263 lb	2080 kg 4586 lb	2620 kg 5777 lb	3500 kg 7716 lb	3950 kg 8708 lb
Number of Cleaner Tines	104	124	160	184	244	304	248	294
Roller Options Available	Crumbler Packer	Crumbler Packer	Crumbler Packer	Crumbler Packer	Crumbler Packer	Crumbler Packer	Crumbler Packer	Crumbler Packer

Dual rotors

Two rotors connected via a single drive.



Front rotor

Tines lift soil and turn into rear rotor to break down soil structure.



Vineyard 1.6m option

A kit is available for restricted and narrow working areas such as orchards and vineyards.



Crumbler roller

Break down soil clods to give a fine finish ready for drilling.



Packer roller

Consolidate and break down soil to reduce soil erosion.



Dyna-Drive Flex

Giving greater versatility and output with working widths up to 6.5m

ACCESSORIES & BOLT-ONS

Fittings & Controls

There are a wide range of fittings and controls to complement your Bomford Turner machine.

Cutting heads range from 950mm to 2m with a choice of flails to suit every application while the many different attachments provide versatile working solutions. Meanwhile, our range of easy-to-use control options offers something for every budget.



Want to know more about our range of Accessories & Bolt-Ons?

Scan the QR code with a smart phone or tablet to instantly view the page.



Fittings & Controls

Heads	92
Attachments	94
Flails	96
Tractor Fittings	98
Controls	100

Heads

Flail head fitting is dependent on the model purchased, with a choice available on most.

The range starts with 950mm cutting width and rises to a full 2m. Most heads offer a choice of 7 flails and the ability to adjust the rotor speed to suit verge or hedge.

Key Features & Options

Hydraulic Roller

Hydraulic Rollers enable the operator to raise the roller to a higher position, remotely from inside the cab when cutting hedge.

Available on **Pro-Trim** and **Pro-Cut**

Double Helix Shaft

Double helix shaft technology (a Bomford innovation) delivers up to 45% overlap of the flails, belt driven protection against unseen debris and close-in cutting.

Available on **Pro-Trim** and **Pro-Cut**

Variable Track Brackets

The new VTB has been designed for operators who need to work in restrictive areas such as narrow lanes - perfect for getting up close and personal to hedges on rural roads and country estates.



Want to know more about our range of Heads?

Scan the QR code with a smart phone or tablet to instantly view the page.

ISMP

The ISMP head enables the whole shaft assembly to be changed saving considerable down time when different flails are required for different jobs. Pro-Trim, Pro-Cut and ISMP heads are equipped with 'Anti Wrap' bearings to reduce the risk of debris fouling the all important rotor bearings.

Available on **Pro-Trim** and **Pro-Cut**

Belt vs Direct Drive

The belt housing on belt driven heads is typically 75mm narrower than the end drive motors enabling the head to get closer in to the hedge or fence. Belt drives offer shock protection when the rotor hits an obstacle where direct shaft driven end drive can shear, resulting in expensive repairs and prolonged down time.



950 LW

The 950 LW head is lighter weight for smaller machines. Direct driven from an end drive motor reducing the overall weight as there is no need for belts and pulleys.

Head Weight	140kg 309lbs
Compatible with	
Raven (74 Litres)	
Kestrel E (74 Litres)	



1107 MW

The 1107 MW heads are of medium weight but with all the advantages that belt drive gives, close-in cutting and damage limitation from unseen obstacles.

Head Weight	145 - 170kg 309 - 375lbs
Compatible with	
Raven (74 Litres)	
Kestrel E (74 Litres)	



1257 LW

The 1257 LW head is lighter weight for smaller machines. Direct driven from an end drive motor reducing the overall weight as there is no need for belts and pulleys.

Head Weight	145 - 170kg 309 - 375lbs
Compatible with	
Robin (50 Litres)	Kestrel E (74 Litres)
Raven (74 Litres)	



Pro-Trim 1.2

The Pro-Trim 1.2 offers double helix shaft technology, belt driven protection and interchangeable shaft operations for speedy flail changes.

Head Weight	240 - 260kg 529 - 573lbs
Compatible with	
Kestrel E (74 Litres)	Hawk (104 Litres)
Kestrel S (88 Litres)	



Pro-Trim 1.5

The Pro-Trim 1.5 offers double helix shaft technology, belt driven protection and interchangeable shaft operations for speedy flail changes.

Head Weight	260 - 300kg 573 - 661lbs
Compatible with	
Hawk (104 Litres)	



Pro-Trim ISMP 1.2

The Pro-Trim ISMP 1.2 has all the features of the Pro-Trim 1.2 but with the addition of ISMP which allows the entire shaft assembly to be changed out saving down time.

Head Weight	240 - 260kg 529 - 573lbs
Compatible with	
Hawk (104 Litres)	



Pro-Cut 1.2

The Pro-Cut 1.2 is made of Domex steel offering double helix shaft technology, belt driven protection and interchangeable shaft operations for speedy flail changes.

Head Weight	280 - 300kg 617 - 661lbs
Compatible with	
Falcon (125 Litres)	B80M (125 Litres)
Buzzard (125 Litres)	B81.81 (125 Litres)
B71 (125 Litres)	Eagle (137 Litres)



Pro-Cut 1.5

The Pro-Cut 1.5 is made of Domex steel offering double helix shaft technology, belt driven protection and interchangeable shaft operations for speedy flail changes.

Head Weight	300 - 340kg 661 - 750lbs
Compatible with	
Falcon (125 Litres)	B80M (125 Litres)
Buzzard (125 Litres)	B81.81 (125 Litres)
B71 (125 Litres)	Eagle (137 Litres)



Pro-Cut ISMP 1.2

The Pro-Cut ISMP 1.2 has all the features of the Pro-Cut 1.2 but with the addition of ISMP which allows the entire shaft assembly to be changed out saving down time.

Head Weight	320 - 350kg 705 - 772lbs
Compatible with	
Falcon (125 Litres)	B80M (125 Litres)
Buzzard (125 Litres)	B81.81 (125 Litres)
B71 (125 Litres)	Eagle (137 Litres)



2m HD Head

The 2m HD head offers the widest cutting width on the market, heavy duty build fitted with an MP44 flail and 150 roller.

Head Weight	450 - 500kg 992 - 1102lbs
Compatible with	
Falcon (125 Litres)	
Buzzard (125 Litres)	



Choosing the right Head

Selecting the right head can seem like a difficult choice given the many options available.

Points to consider include:

- Compatibility with your arm mower
- Frequency of operation
- Grass or hedge cutting

For further information please speak to one of our experienced team.

Attachments

A wide selection of attachments is available to improve the versatility and therefore the profitability of the Bomford arm mowers range.

Bomford attachments are built with the same attention to detail and robust qualities that you have come to expect from the Bomford machinery range.

Key Features

- Simple square section mounting
- Simple hydraulic connection
- Vast choice of attachments to maximise usage from your arm mower



Want to know more about our range of Attachments?

Scan the QR code with a smart phone or tablet to instantly view the page.



Rotary Heads

Ideal for longer growth material. Available with blades or heavy-duty chain cutting options, operating in either vertical or horizontal plane, its 2.25msq cutting area makes short work of even the most challenging tasks.

Head Weight	380 - 450kg 838 - 992lbs
Compatible with	
Falcon (125 Litres)	Buzzard (125 Litres)



Weed Brush

Removes wild herbs and weeds on open cycling paths, pavements and road verges. The debris is moved to the side as the head travels forward.

Head Weight	145 - 170kg 320 - 375lbs
Compatible with	
Kestrel S (88 Litres)	Buzzard (125 Litres)
Hawk (104 Litres)	Eagle (137 Litres)
Falcon (125 Litres)	



Pro-Saw

With widths of 1.5m (3 blade), 2.0m and 2.5m (4 blade), the Pro-Saw is capable of cutting through branches of up to 20cm (8").

Head Weight	145 - 170kg 320 - 375lbs
Compatible with	
Raven (74 Litres)	Falcon (125 Litres)
Kestrel E (74 Litres)	Buzzard (125 Litres)
Kestrel S (88 Litres)	Eagle (137 Litres)
Hawk (104 Litres)	



Ditch Cleaner

Designed for use with a range of side-arm mowers, simplifying the maintenance of roadside ditches and grips. Two models are available, manual or hydraulic.

Head Weight	240 - 260kg 529 - 573lbs
Compatible with	
Hawk (104 Litres)	Eagle (137 Litres)
Falcon (125 Litres)	
Buzzard (125 Litres)	



Heavy Sheartrim

For cutting material up to 100mm (4").

Head Weight	250-280kg 551 - 617lbs
Compatible with	
Kestrel E (74 Litres)	Falcon (125 Litres)
Kestrel S (88 Litres)	Buzzard (125 Litres)
Hawk (104 Litres)	Eagle (137 Litres)



Debris Blower

Controlled from within the cab and driven by its own hydraulic motor, the fully adjustable Debris Blower effortlessly removes hedge and verge trimmings from the roadside.

Attachment Weight	80kg 176lbs
Compatible with	
Kestrel E (74 Litres)	Falcon (125 Litres)
Kestrel S (88 Litres)	Buzzard (125 Litres)
Hawk (104 Litres)	

Medium Sheartrim

For cutting material up to 40mm (1 1/2").

Head Weight	240 - 260kg 529 - 573lbs
Compatible with	
Raven (74 Litres)	Falcon (125 Litres)
Kestrel E (74 Litres)	Buzzard (125 Litres)
Kestrel S (88 Litres)	Eagle (137 Litres)
Hawk (104 Litres)	



Collector Head

Ingenious design combining a conventional flail head and rotor, along with a twin helical auger collecting flail cuttings. Suction hose and vacuum trail can be fitted (not included).

Head Weight	420kg 926lbs
Compatible with	
Falcon (125 Litres)	

Sheartrims

Reciprocating cutter bars for cutting material in enclosed areas where the cut material needs to be controlled. A range of sizes are available.

Standard Sheartrim

For cutting material up to 25mm (1").

Head Weight	180-240kg 397 - 529lbs
Compatible with	
Raven (74 Litres)	Falcon (125 Litres)
Kestrel E (74 Litres)	Buzzard (125 Litres)
Kestrel S (88 Litres)	Eagle (137 Litres)
Hawk (104 Litres)	



Hydraulic Roller

Easy roller adjustment without leaving the cab. A simple tractor spool operated twin ram system allows adjustment during continuous work on either grass or hedge cutting.

Attachment Weight	280-380kg 617 - 838lbs
Compatible with	
Pro-Trim 1.2	Pro-Cut 1.2
Pro-Trim 1.5	Pro-Cut 1.5



Choosing the right Attachment

Selecting the right attachment can seem like a difficult choice given the many options available.

Points to consider include:

- Compatibility with your arm mower
- Style/type of operation looking to perform
- Available budget

For further information please speak to one of our experienced team.

Flails

Over the decades we have designed, adapted and invented a range of flails for our cutting heads to suit every purpose.

The vast majority of our heads now offer the ability to fit any one of these ten flails. Some are available as standard and some are optional. The rotors in our flail heads have a twin helical pattern, giving a wider flail overlap than previous models and our competitors, ensuring a cleaner, more complete cut.

Choosing the right Flail

Selecting the right flail can seem like a difficult choice given the many options available. All of our flails will fit onto the same rotor apart from the Bushmaster which requires a heavier duty rotor because of the weight. Points to consider include:

- Frequency of cut
- Material to cut – grass, hedges or a combination of both

Flail layouts

All our flails are mounted in a helical pattern around the cutting rotor. The choice of flails for intended purpose and number are dictated by the size and model of the head they are intended for.

For further information please speak to one of our experienced team.



Flail Compatibility Options

● Standard ○ Optional — Not Available

Flails	No. of Flails	BB	MP44	HS60	Pro Flail	T40	T 60	True Cut	Match Cut	Bushmaster Open	Bushmaster Closed
Compatible with											
950mm LW with 102mm roller	28	●	●	●	—	—	—	—	—	●	●
1257mm LW with 102mm roller	36	○	○	●	—	—	—	—	—	—	—
1257mm LW with 150mm roller	36	○	●	○	—	—	—	—	—	—	—
1107mm LW with twin back to back 115mm roller	32	●	○	○	—	—	—	—	—	—	—
1.2m Pro-Trim with 115mm roller	32	○	○	○	○	○	○	○	○	—	—
1.2m Pro-Trim with 150mm roller	32	○	○	○	○	○	○	○	○	—	—
1.5m Pro-Trim with 115mm roller	40	○	○	○	○	○	○	○	○	—	—
1.5m Pro-Trim with 150mm roller	40	○	○	○	○	○	○	○	○	—	—
1.2m Pro-Trim ISMP with 115mm roller	24	○	○	○	○	○	○	○	○	●	●
1.2m Pro-Trim ISMP with 150mm roller	24	○	○	○	○	○	○	○	○	●	●
1.2m Pro-Cut with 115mm roller	32	○	○	○	○	○	○	○	○	○	○
1.2m Pro-Cut with 150mm roller	32	○	○	○	○	○	○	○	○	○	○
1.5m Pro-Cut with 115mm roller	40	○	○	○	○	○	○	○	○	○	○
1.5m Pro-Cut with 150mm roller	40	○	○	○	○	○	○	○	○	○	○
1.2m Pro-Cut ISMP with 115mm roller	32	○	○	○	○	○	○	○	○	○	○
1.2m Pro-Cut ISMP with 150mm roller	32	○	○	○	○	○	○	○	○	○	○
2m HD Head	54	○	●	—	—	—	—	—	—	—	—



Want to know more about our range of Flails?

Scan the QR code with a smart phone or tablet to instantly view the page.



BB Flail 40mm

Narrow profiles and sharp cutting edges give a clean cut with low power consumption.



MP44 Multi Purpose Bootee Flail

Dual purpose flail cuts material up to 30mm (1 1/2").



HS60 Bootee Flail

Dual purpose flail will cut up to 35mm (1 1/2"). Interchangeable with the 'T' Flail 60mm.



Pro Flail 40mm

Multi-purpose flail for annual hedge trimming and vegetation control.



T Flail 40mm

Dual purpose flail will cut material up to 30mm (1 1/2").



T Flail 60mm

Create an excellent finish on hedges from six months growth to 50mm (2") thick. Interchangeable with the HS60 Bootee Flail.



True-Cut

More pronounced leading edge on the shaft removes unwanted build-up of material and allows more efficient cutting.



Match Cut 60mm

Suitable for heavy growth, this flail produces the cleanest cut on all types of material.



Bushmaster Open

A heavy-duty (open) flail for cutting growth up to 100mm (4") it is perfect for three year hedge growth or brush cutting.



Bushmaster Closed

A heavy-duty (closed) flail for cutting growth up to 100mm (4") it is perfect for three year hedge growth or brush cutting.

Tractor Fittings

All Bomford hedge cutters attach to the tractor using 1 or 2 styles of mounting systems.

System 1

Three point linkage kits that allow quick and easy attachment to the tractor using the standard three point mounting and machine support frame. There are 4 types of three point mounting kits:

- Chain Stabiliser Kit
- A Frame
- Three Point Linkage
- Four Point Linkage
- Heavy Duty Linkage

System 2

Axle brackets allow rigid mounting of the machine to the tractor with no sway or movement between tractor and machine. The axle brackets are attached to the underside of the tractor's rear axle.

- Axle Bracket
- Subframe



Want to know more about our range of Tractor Fittings?

Scan the QR code with a smart phone or tablet to instantly view the page.



SYSTEM 1: Chain Stabiliser Kit

A simple and cost-effective solution. Fitted using "key hole" plates on the top link and lower link pins, the working height is selected on the tractor hydraulics, chains are slotted through the key hole plates and become tight and control lateral stability when weight is lowered.

Compatible with:
Raven, Kestrel E, Osprey



SYSTEM 1: A Frame

A fixed mounting fitted to the tractor's top link clevis, this is a simple and secure way of linking various attachments. The frame can be bolted to the machine using one of the series of attachment holes and check chains tightened to prevent sideways movement.

Compatible with:
Microklippa, Robin



SYSTEM 1: Three Point Linkage

This popular type of mounting frame is fitted to the machine before fitting to the tractor and is compatible with a wide range of tractor makes and models. The tractor's 3-point linkage is then attached to the machine and the mounting frame for secure linkage with check chains tightened to prevent sideways movement.

Compatible with:
Osprey, Kestrel, Hawk



SYSTEM 1: Four Point Linkage

This mounting frame uses the conventional 3-point linkage but also connects to the tractor's pick-up hitch to create additional stability and rigidity when working.

Compatible with:
Kestrel S, Hawk, Falcon



SYSTEM 1: Heavy Duty Linkage

Heavy duty three-point linkages provide maximum stability for larger arm mowers. This linkage is suitable for Cat 11 and Cat 111, and for machines up to 6.5m reach. It can also be used in conjunction with a tractor's Euro type hitch.

Compatible with:
Hawk 6.5T, Falcon



SYSTEM 2: Axle Bracket

Axle brackets are incorporated, where necessary, with stabiliser and cab suspension mounting positions and allow rigid mounting of the machine to the tractor with no sway or movement.

Compatible with:
Hawk, Falcon, Buzzard, B81-81, B71M, Eagle



SYSTEM 2: Subframe

On Kestrel S, Hawk and Falcon machines, the sub-frame and axle brackets may be specified as an alternative to the three-point mounting system while on all Buzzard and Eagle machines axle mount is standard.

Compatible with:
Hawk, Falcon, Buzzard, B81-81, B71M, Eagle

Choosing the right Fittings

Points to consider when choosing the right fitting include:

- Compatibility of machine to tractor
- Length of reach on the arm mower being fitted (we generally recommend axle brackets for over 6.5m arms)
- Frequency that machine will be removed from tractor

For further information please speak to one of our experienced team.



Controls

With a focus on ease of operation, our control options provide a suitable solution to accommodate your personal requirements and suit various budgets.

Control options range from the simple, much-used cable control through to the fully adjustable ICS Intelligent Control System that can be programmed/personalised by the operator.

Key Features

- Simple mounting systems
- Easy operation
- Full instruction manuals



Want to know more about our range of Controls?

Scan the QR code with a smart phone or tablet to instantly view the page.



Control Compatibility Options

● Standard ○ Optional — Not Available

Controls	ICS 4	EPP 4	LPH	EPC	CC
Compatible with					
Microklippa	—	—	—	○	●
Wren	—	—	—	—	●
Robin	—	—	—	○	●
Raven	—	—	○	—	●
Osprey	—	○	○	—	●
Kestrel Evo 'E'	—	○	○	—	●
Kestrel Evo 'S'	○	○	○	—	●
Kestrel Evo 'S' Forward	○	○	○	—	●
Kestrel Evo 'S' Front Mounted	●	○	—	—	—
Hawk Evo	○	○	○	—	●
Hawk Evo Forward	○	○	○	—	●
Hawk Evo VFA	○	○	—	—	—
Falcon Evo	○	○	○	—	●
Falcon Evo Forward	○	○	○	—	●
Falcon Evo VFA	○	○	—	—	—
Front Mount Range	○	○	—	—	●
Buzzard Evo	●	—	—	—	—
Buzzard Evo Forward	●	—	—	—	—
B71 & B80M	●	○	—	—	—
B81.81	●	○	—	—	—
Eagle	●	—	—	—	—



ICS 4 - Intelligent Control System

With the added functionality of a colour TFT screen, with larger viewing area, upgraded menus and fault diagnostics, along with arm mower speed adjustment system, the finger tip proportional joystick gives smooth and agile control to the operator.



EPP 4 - Electronic Proportional

Now in its 4th generation, it shares the robust control box housing of the ICS controls. The ultimate in electronic controls, fitting well on all models in the range. It is a firm favourite with farmers and contractors.



LPH - Low Pressure Hydraulics

A robust proportional alternative. With a larger control joystick, it is well suited to machines with multiple occasional users, or for someone upgrading to their first joystick control. Simple operation, and easy to use.

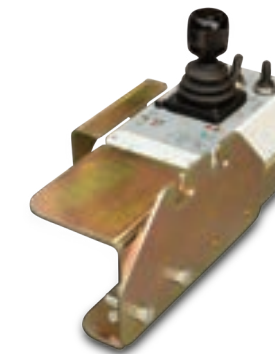

EPC - Electronic Proportional

A proportional control option for the smaller compact range. Professional operation with fingertip controls, but in a compact sized housing, making mounting to smaller compact tractors simpler.



CC - Low Friction Cable Controls

The original remote cable control. Using a series of low friction cable controls in conjunction with a remote hydraulic valve. A simple lever arrangement gives individual control of each hydraulic ram cylinder.



Choosing the right Controls

Points to consider when choosing the right control include:

- Budget – cost of control upgrade
- Ease of use over long periods of time
- Mounting positions in cab

For further information please speak to one of our experienced team.

Service & Support

Should you require any assistance with operation or repair our service and support team are on hand to help.

Technology experts

Bomford service engineers are experts in our technology. Backed by extensive training and a fully-equipped mobile workshop, they provide an unrivalled level of product knowledge and back-up, to deliver fast and effective cover across the country.

World class sales support

We can offer specialist advice direct from the manufacturer, one-to-one consultations with experienced sales professionals and expert guidance on creating new machines to precise personal specifications.





Conditions of sale

Prices and specification are subject to change without notice.
All goods will be invoiced at price ruling at the date of dispatch.
Prices quoted in the price list do not include VAT.

The buyer will bring to the attention of those who use the goods all instructions provided by the seller on their use (including all safety precautions to be taken) and will ensure that they have the necessary skills and understanding in respect of their use. Save the extent otherwise provided in section 2 of the unfair contract terms act; the buyer will protect the seller against any failure by the buyer to carry out this obligation.

While every effort has been made to ensure the accuracy of the information at the time of printing, Bomford Turner accepts no liability due to any errors or omissions present in this literature. Bomford Turner reserves the right to make any changes to product specification outside any of those listed in this price list.

Contact Us

UK Sales

Ashley Anson
UK Sales Manager - Central North & Scotland
Office Tel: +44 (0)1789 773383
Office Fax: +44 (0)1789 773238
Mobile: +44 (0)7774 855580
Email: aanson@bomford-turner.com

Paul Clayton
Area Sales Manager - South & East
Office Tel: +44 (0)1789 773383
Office Fax: +44 (0)1789 773238
Mobile: +44 (0)7768 553800
Email: pclayton@bomford-turner.com

Rhys Thomas
Area Sales Manager - Midlands, Wales & Southwest
Flailbot Specialist
Office Tel: +44 (0)1789 773383
Office Fax: +44 (0)1789 773238
Mobile: +44 (0)7817 137068
Email: rthomas@bomford-turner.com

Debbie Winters
Sales Administration Manager
Office Tel: +44 (0)1789 773383
Office Fax: +44 (0)1789 773238
Email: dwinters@bomford-turner.com

Export Sales

Craig Whiting
Export Sales Manager
Office Tel: +44 (0)1789 773383
Office Fax: +44 (0)1789 773238
Mobile: +44 (0)7813 137451
US Mobile: +1 (830)327-2400
Email: cwhiting@bomford-turner.com

Ole Buhl
Northern Europe Sales Manager
Office Tel: +44 (0)1789 773383
Office Fax: +44 (0)1789 773238
Mobile: +45 40 35 89 71
Email: obuhl@bomford-turner.com

Tom Dale
Export Sales Administration
Office Tel: +44 (0)1789 773383
Office Fax: +44 (0)1789 490123
Email: tdale@bomford-turner.com

Parts

David Rimmer
Parts Sales Manager
Office Tel: +44 (0)1789 773383
Office Fax: +44 (0)1789 490123
Mobile: +44 (0)7725 163728
Email: drimmer@bomford-turner.com

Rory Stowe
Parts Assistant
Office Tel: +44 (0)1789 773383
Office Fax: +44 (0)1789 490123
Email: rstowe@bomford-turner.com

Service

Mark Cresswell
Service Manager
Office Tel: +44 (0)1789 773383
Office Fax: +44 (0)1789 490123
Mobile: +44 (0)7815 189267
Email: mccresswell@bomford-turner.com

Gavin Stockley
Service Engineer
Office Tel: +44 (0)1789 773383
Office Fax: +44 (0)1789 490123
Mobile: +44 (0)7815 123165
Email: gstockley@bomford-turner.com

Kevin Hiatt
Service Engineer
Office Tel: +44 (0)1789 773383
Office Fax: +44 (0)1789 490123
Mobile: +44 (0)7813 137457
Email: khiatt@bomford-turner.com



Bomford Turner Limited
Station Road, Salford Priors,
Nr. Evesham, Worcestershire
WR11 8SW
United Kingdom

Tel **+44 (0) 1789 773383**
Fax **+44 (0) 1789 773238**
E-mail **info@bomford-turner.com**
Website **www.bomford-turner.com**

